

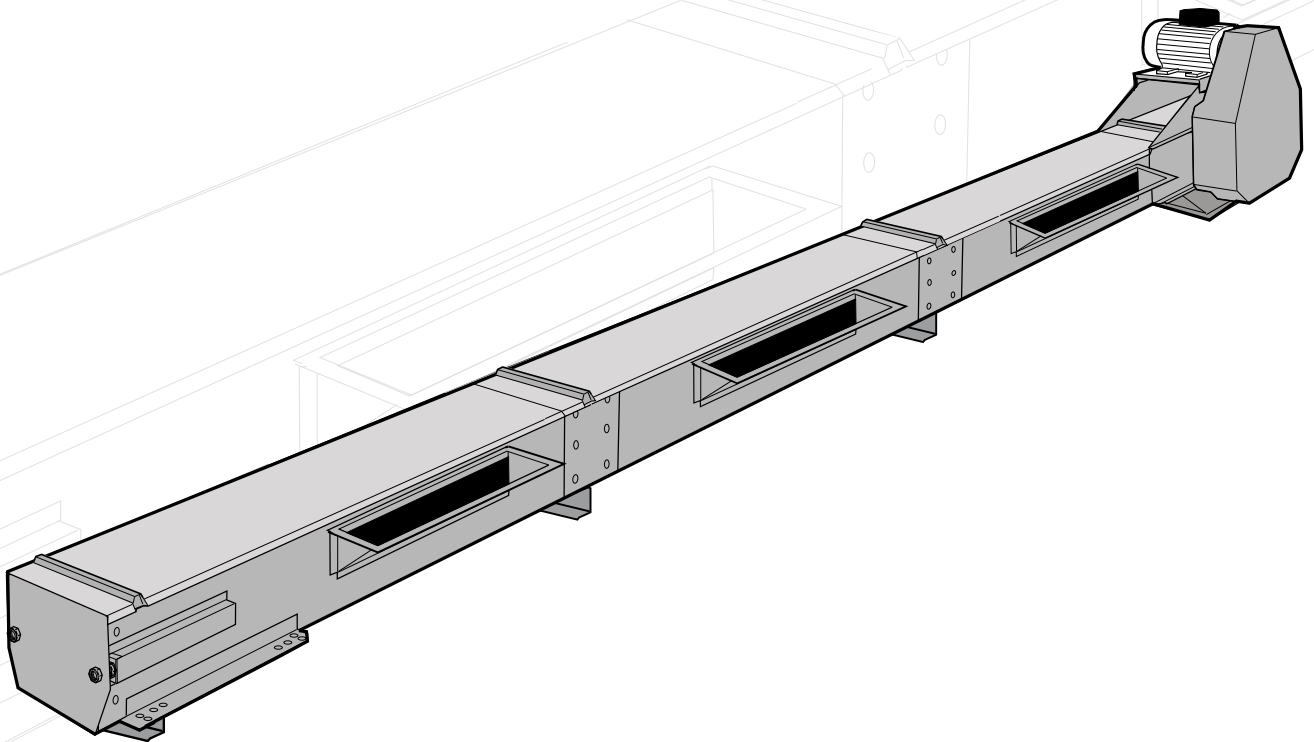

# KTFb





## Goods inspection

Check that the number of packages agrees with the delivery note and that the packing and goods are not damaged. Make a note of any damage and missing materials on the consignment note and report it to the carrier and to us. Make sure the delivery is complete after unpacking the goods. Any materials that are found to be incorrect must not be assembled.

## Warranty

A 2-year factory warranty from the day of delivery applies to all models of Skandia Elevator AB machinery. A condition of the warranty and any subsequent compensation is that Skandia Elevator AB is contacted and an agreement reached between the customer and Skandia Elevator AB on how any faults should be rectified. The warranty covers all parts that are damaged or break due to faulty design or manufacture. Faults and damage caused by faulty assembly, incorrect use or lack of maintenance will not be covered by the warranty.

## CE mark

A CE mark is located on the transmission side of the drive and is proof that the machine has been manufactured in accordance with EU machine directives and complies with safety requirements. The CE mark contains information concerning year of manufacture, model designation and order number. Always specify the order number in the event of a claim and on orders for spare parts.

## EC Declaration

Skandia Elevator AB  
Arentorp  
S-53494 Vara  
SWEDEN

declare under our sole responsibility that the product:

## KTFb

order number:

.....  
to which this declaration relates is in conformity with Council Directive of 29 December 2009 on the harmonisation of the member States relating to machinery, 2006/42/EC.

Unless otherwise specified on the CE mark, the product is manufactured in accordance with EU Machinery Directive and is classified as Category II 2D/OD. It is intended for the transport of materials that correspond with ATEX Zone 21 and the external environment is unclassified.

Vara 29/12 2009

Joakim Larsson, CEO



## Thank you for choosing Skandia Elevator!

Your conveyor system must be assembled correctly and maintained thoroughly if it is to operate satisfactorily. These assembly instructions and the separate maintenance instructions must be followed for the warranty to apply.

We hope you will be pleased with your Skandia conveyor equipment for a long time.

<b>Machine overview</b> .....	<b>6</b>
<b>Safety information</b> .....	<b>7</b>
General safety information .....	7
Electrical safety .....	8
Safety decals .....	9
<b>Before assembly</b> .....	<b>11</b>
Inclination of horizontal conveyor .....	12
Transport in both directions .....	12
<b>Connection of the machine</b> .....	<b>16</b>
Inlet .....	16
Inlet in raised lid with intermediate tray .....	17
Connection to inlet in horizontal section .....	18
Connection between side inlet and storage bin .....	19
Connection to subsequent machine .....	19
<b>Assembling the machine</b> .....	<b>20</b>
<b>Assembling the motor</b> .....	<b>28</b>

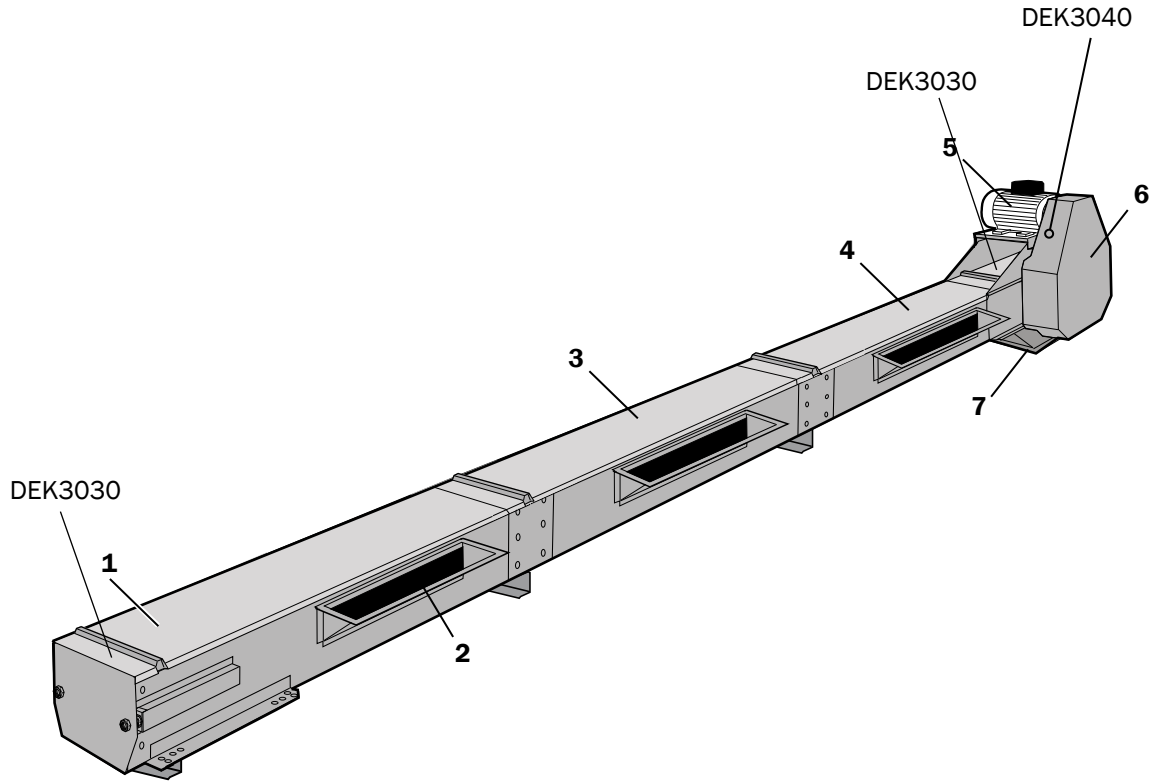

Parts	Pos.
Tail end	1
Side inlet	2
Intermediate section	3
Drive	4
Motor	5
Transmission with guard	6
Outlet	7
Safety decals	DEK.XXXX

The owner of the transport equipment is responsible for these assembly instructions always being available to the fitters, electricians, maintenance technicians and engineering technicians concerned.

Incorrect assembly and/or operation may lead to personal injury or damage to the conveyor equipment and/or other equipment. It can also cause malfunctions or a reduction in capacity.

Read the assembly instructions carefully before assembly, electrical connection, maintenance or operation commences. If any part of these instructions should be difficult to comprehend, please get in touch with your reseller for assistance.

The safety information is presented and interpreted as follows:

**⚠ WARNING!**

Disregarding instructions given in warnings can cause serious personal injury or death.

**⚠ IMPORTANT!**

Ignoring the instructions given in important texts may cause damage to the conveyor equipment and/or other equipment. It can also cause malfunctions or a reduction in capacity.

NB! indicates that the text contains information that will simplify the assembly process.

## General

**⚠ WARNING!**

- Ensure that everyone responsible for assembly, electrical connection, maintenance and operation of the conveyor equipment has read and understood the instructions and safety information.
- Use protective gloves, helmet, steel-toed boots, ear defenders, protective goggles and high-vis vest when carrying out assembly, electrical connection, maintenance and operation of conveyor equipment.



### **WARNING!**

- Stop the machinery and turn off electric power before attempting any type of assembly, electrical connection or maintenance work.
- Do not start the machinery without the lid, hatches, covers, guards and connections fitted in such a way they can only be opened with tools.
- Connections to, from and between machinery must be permanently mounted and fully enclosed. If the design of the installation does not allow this at an outlet, finish off with a 1 m pipe.

### **IMPORTANT!**

- If the machine is being assembled outdoors, the motors and transmissions must be fitted with a weather cover.
- Conveyors with intermediate trays in the conveyor sections cannot be operated in both directions unless the raised lid projects at least 400 mm in both directions from the intermediate tray.
- If a short circuit should occur, ensure that the electrical equipment is in working order before continuing operation.
- Ensure that the electrical equipment is kept free from dirt, dust, moisture and electrostatic charge.
- The machine is not designed to stand or walk on.

## Electrical connection

Incorrect electrical connection may lead to personal injury or damage to the conveyor equipment and/or other equipment. It can also cause malfunctions or a reduction in capacity.

### **WARNING!**

- All electrical equipment is to be connected by a qualified electrician. See separate connecting directions for electronics.
- The power switch must be permanently mounted and located to allow easy access when carrying out maintenance work.
- Ensure the safety switch for the pop up overloading flap (optional accessory) is engaged during operation.

### **IMPORTANT!**

- Ensure the motor protection is set to the correct ampere setting for the motor.
- Ensure the chain switch (optional accessory) is engaged during operation.

## Maintenance

Inadequate maintenance may lead to personal injury or damage to the conveyor equipment and/or other equipment. It can also cause malfunctions or a reduction in capacity.

### **WARNING!**

Read the separate maintenance instructions before taking the machine into service.



## Safety decals

### **WARNING!**

The machine is supplied with safety decals on delivery. They must not be removed or defaced. If a safety decal becomes damaged, you can order a new one free of charge from Skandia Elevator AB. Specify the part number of the decal. See the section below and the previous chapter Machine Overview.





#### There are safety decals for:





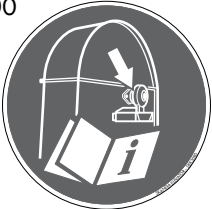

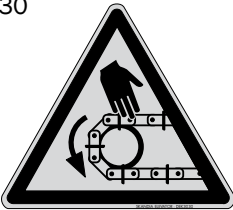

- Mandatory (white symbol on round blue background).
- Forbidden (black strike-through symbol on round white background with red surround).
- Warning (black symbol on triangular yellow background with black surround).

### **WARNING!**

The mandatory instruction, forbiddance or warning given on all safety decals must be considered or serious injury or death may follow.

Skandia Elevator machines have the following safety decals:

<b>Part number/Safety decal</b> Refer to the "Machine Overview" chapter for placement.	<b>Written definition</b>
DEK3090 	Read the "Back stop" section in the elevator's assembly instructions before test starting the motor for the first time.
DEK3100 	Do not place the valve with the motor side face down.
DEK3140 	Changing settings and equipment is prohibited.
DEK3030 	Warning for conveyor chain!
DEK3060 	Warning for bucket belt!

<p>DEK3040</p> 	<p>Warning for chain drive!</p>
<p>DEK3050</p> 	<p>Warning for belt drive!</p>
<p>DEK3070</p> 	<p>Warning for rotating conveyor drive shaft!</p>
<p>DEK3080</p> 	<p>Warning for rotating elevator drive shaft!</p>
<p>DEK3110</p> 	<p>Warning for moving machinery!</p>
<p>DEK3120</p> 	<p>Warning for moving machinery!</p>
<p>DEK3010</p> 	<p>Warning for dust explosion!</p>
<p>DEK3130</p> 	<p>Warning, a maximum of 2 people = 200 kg/440 lbs may be on the platform and ladders simultaneously!</p>

The conveyor can be assembled directly in place in the installation or separately and then lifted in place. The design and space requirements of the installation and the length of the conveyor will determine which method is most suitable.

**⚠ IMPORTANT!**

- Ensure the machine is situated correctly in relation to the planned connections.
- The conveyor length must not exceed 14 metres if being lifted after assembly. Its weight must be distributed over several lifting points with one supporting the support frame of the drive. The distance between the lifting points must be a maximum of 12 metres.
- The maximum span between supports for a standard conveyor is 6 metres. This distance is 12 metres if cable supports are used.
- Relieve the weight of the drive with braces to the ground and/or a nearby stable construction. If the machine has a geared motor, brace its support frame. Never use the motor/geared motor to brace on.

bolts for assembling the conveyor are in the bag fastened to each machine part.

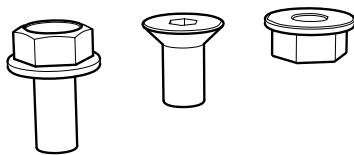

This machine is available in several different models:

A - with inlet for feeding from another machine or shutter-controlled feeding from a silo/storage bin.

B - with side inlet for self-regulated feeding from storage bin.

C & D - with inlet in intermediate section with raised lid and intermediate tray for self-regulating feeding from silo/storage bin.

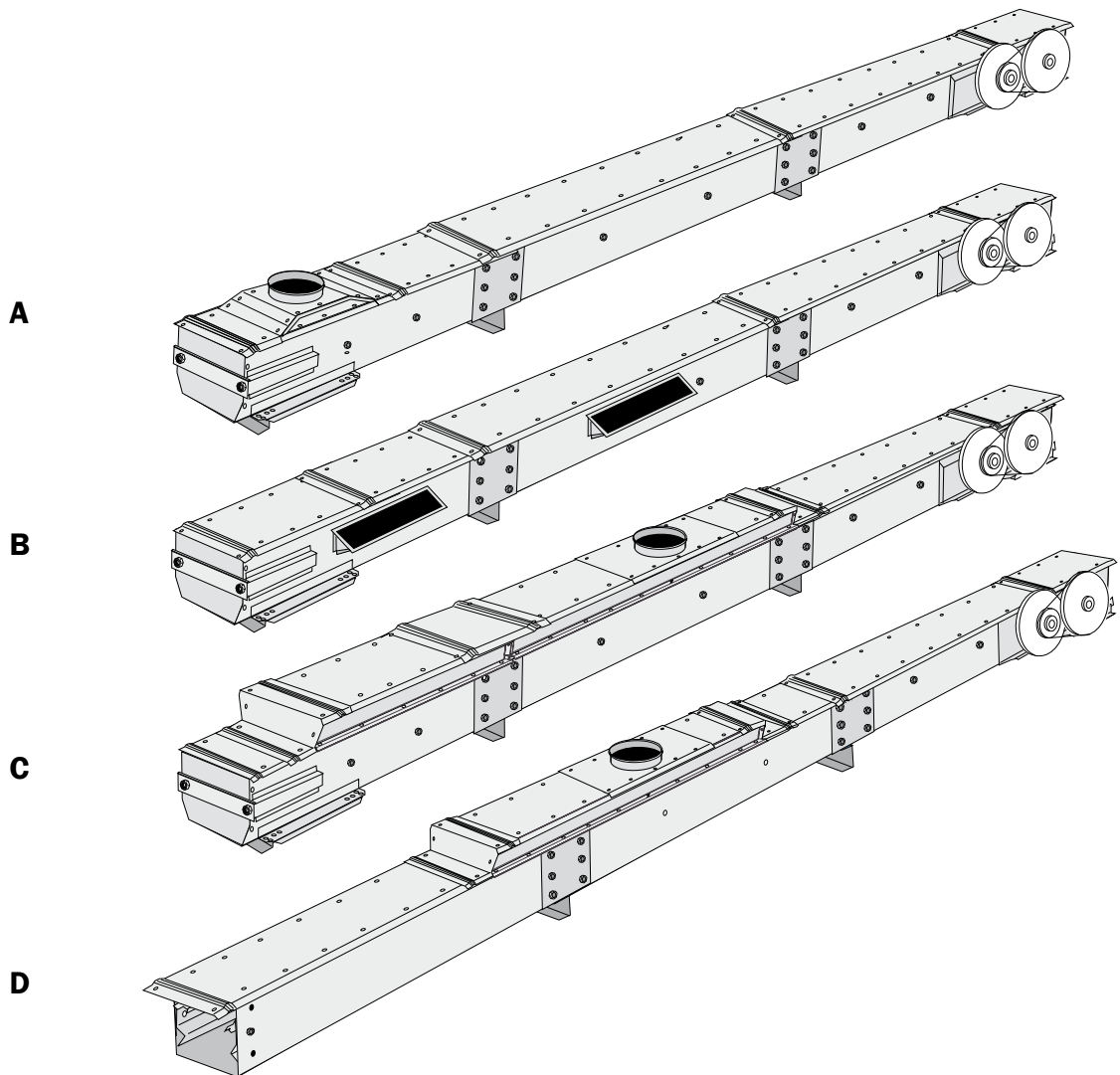

1.  
Lay out the machine parts in the order they are to be assembled.
2.  
Remove lid plates, intermediate trays and guide rails as illustrated.

The illustration shows:

ABD1 - Tail end for versions A, B and C.

C1 - Tail end for version C.

AD2 - Intermediate section for versions A and D.

B2 - Intermediate section for version B.

C2 - Intermediate section for version C.

ABD3 - Drive for all versions.

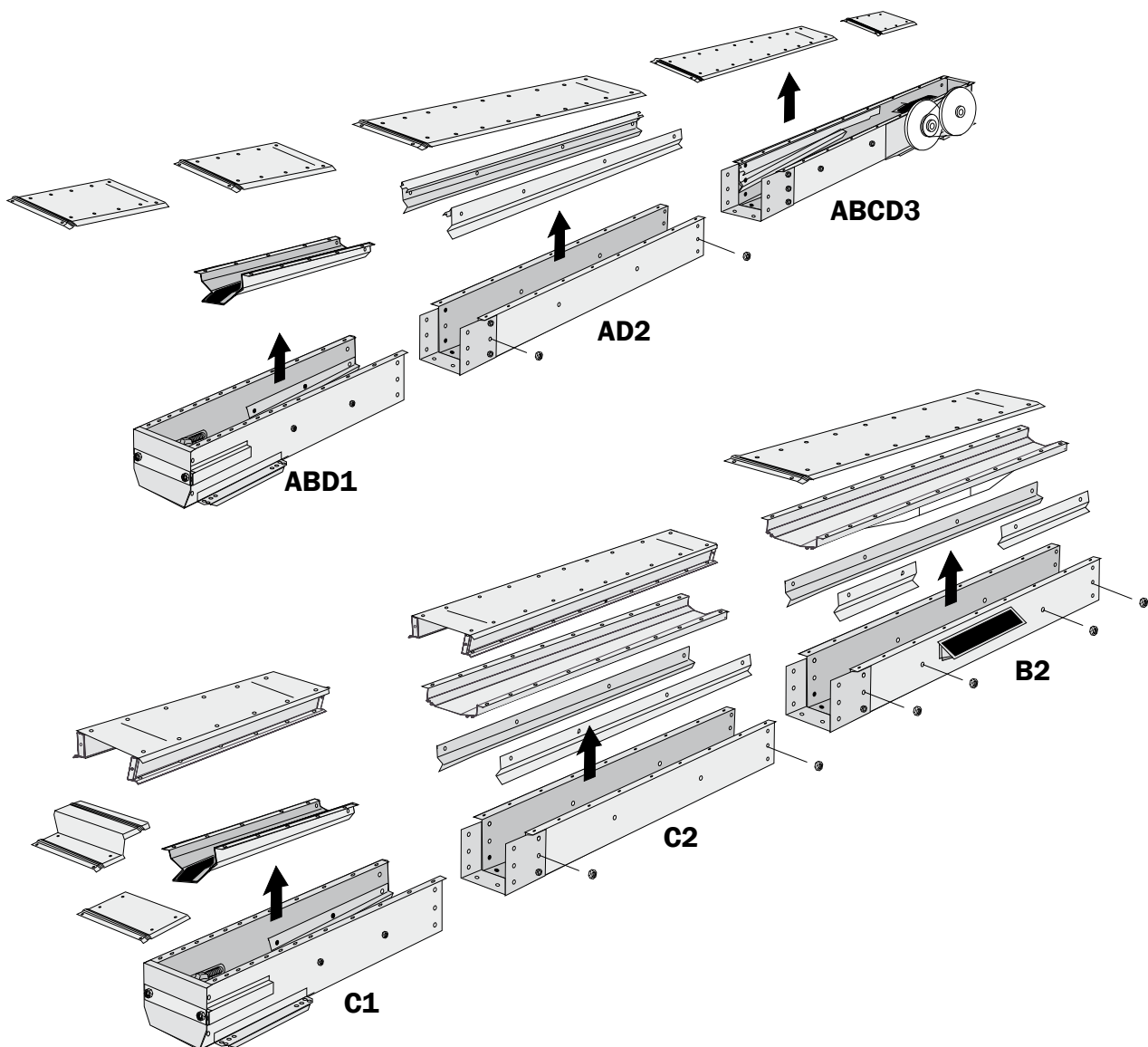

## Inclination of horizontal conveyor

The capacity of a horizontal conveyor will be reduced if it is assembled at an inclination exceeding 5°.

### **IMPORTANT!**

If a conveyor must be inclined more than 5°, a conveyor designed for inclined operation must be used.

## Transport in both directions

### **IMPORTANT!**

- Conveyors with intermediate trays in the conveyor sections cannot be operated in both directions unless the raised lid projects at least 400 mm in both directions from the intermediate tray.
- The longest stretch of conveyor must always be aligned towards the drive. The length of transport must not exceed 20 metres in the other direction.
- The conveyor chain tension must be checked often when transport is in both directions.



## ⚠ **WARNING!**

- Connections to, from and between machinery must be permanently mounted and fully enclosed. If the design of the installation does not allow this at an outlet, finish off with a 1 m pipe.
- Unused inlets are to be sealed.

## ⚠ **IMPORTANT!**

- Use only recommended inlet, outlet and connecting components.
- Ensure the ducting is dimensioned sufficiently and that its angle of inclination is at least 45°.

Assemble the inlet/outlet as instructed in the section "Assemble the machine".

## Inlet

The inlet is used when feeding from a machine with customised capacity.

## ⚠ **IMPORTANT!**

When feeding from a silo or storage bin, an inlet in raised lid with intermediate tray should be used.

The inlet in the tail end can be positioned to illustrated dimensions.

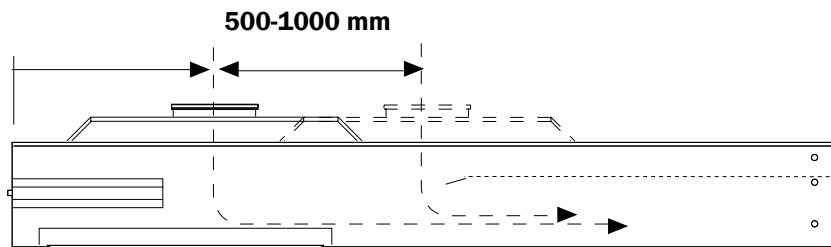

Inlets can also be located further in toward the intermediate section if a tail end with raised lid is used. See illustrated dimensions.

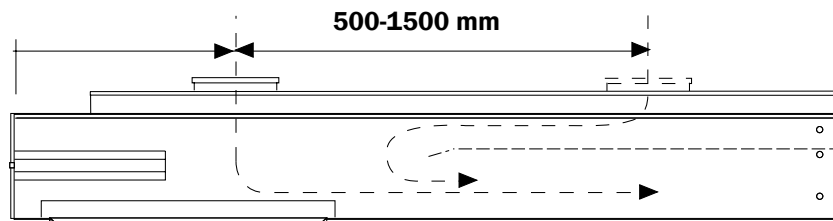

Inlets in intermediate sections can be located anywhere along its entire length.

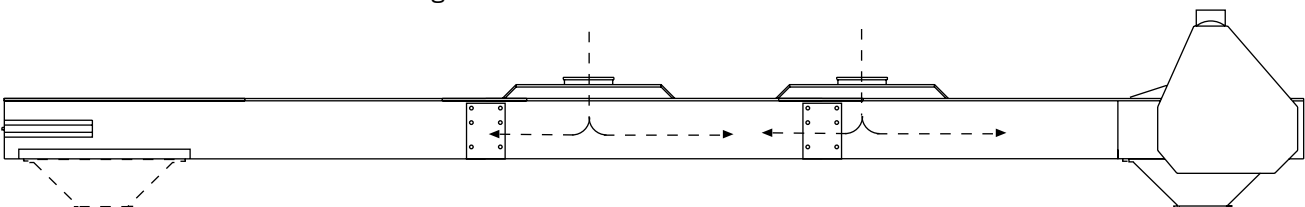



## Inlet in raised lid with intermediate tray

Inlets of this type are self-regulating and are used for feeding from silo or storage bin.

Inlets of this type can be positioned to illustrated dimensions.

### **IMPORTANT!**

Fit a raised lid displaced 400 mm towards the tail end.

If an intermediate section with raised lid is to be assembled directly to the tail end, the tail end must also be of the raised lid type.

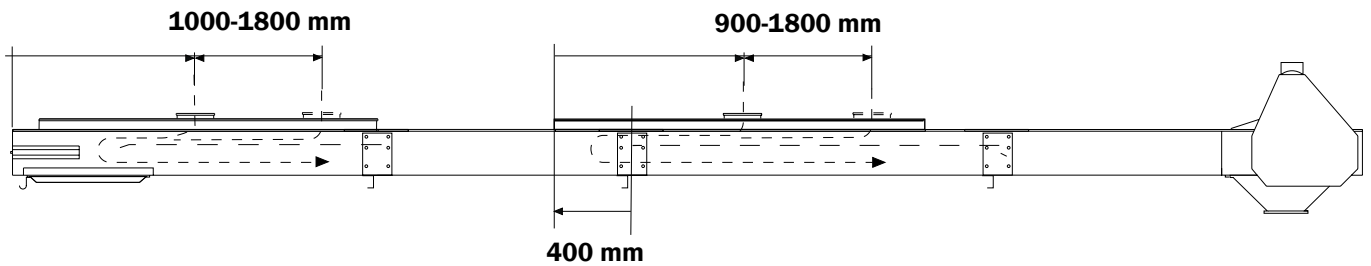

Side inletSide inlets are self-regulating and used for feeding from a silo/ storage bin.

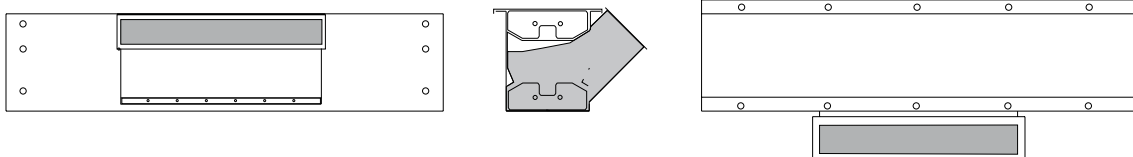

## Connection to inlet in horizontal section

### ⚠ **IMPORTANT!**

The connection is to be designed so that the feeding is vertical in relation to the plane of the conveyor.

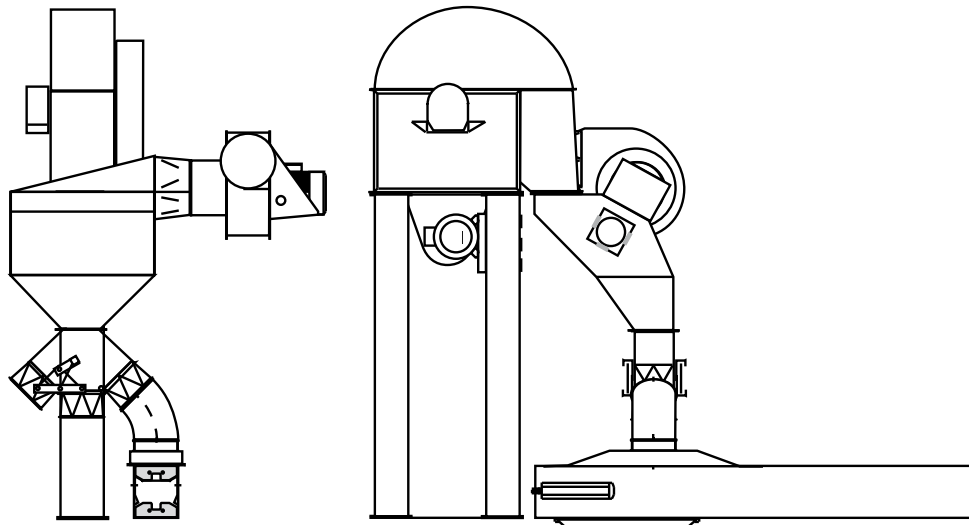
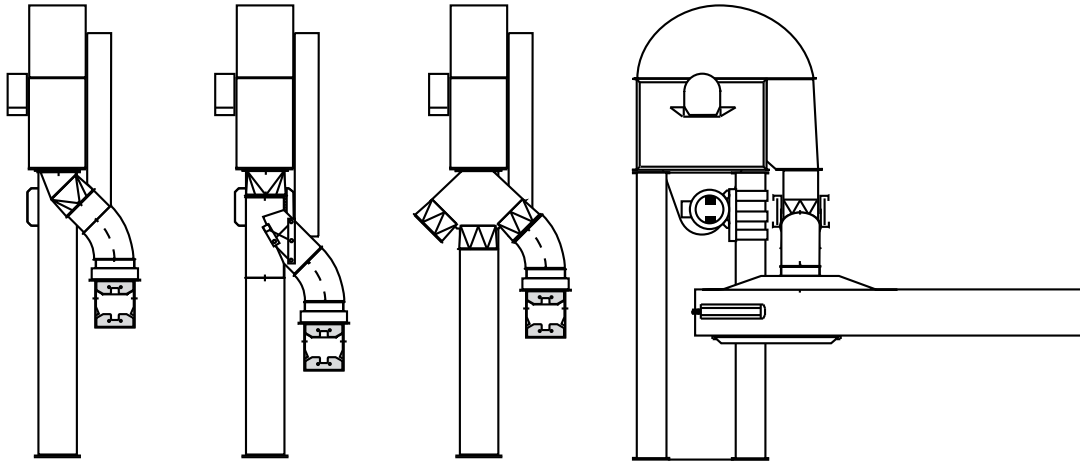

## Connection between side inlet and storage bin

### **IMPORTANT!**

The connection must be inclined at least 45° in relation to the plane of the conveyor.

## Connection to subsequent machine

Connect the conveyor to the subsequent machine according to its assembly instructions.

1.  
Push together the machine parts.

**⚠ IMPORTANT!**

Ensure the machine parts are assembled in a straight line and are not twisted.

2.  
Fit the bottom bolts.

NB! Fit support legs (Y) at the same time as the bottom bolts.

3.  
Fit the side bolts.

NB! Use only the upper and lower holes towards the intermediate sections with guide rails and only the lower holes towards intermediate sections with guide rails and intermediate trays. Use only the middle and the lower holes towards the tail end.

**⚠ IMPORTANT!**

When assembling outdoors, the joints in the side plates, lid and inlet must be sealed with silicone.

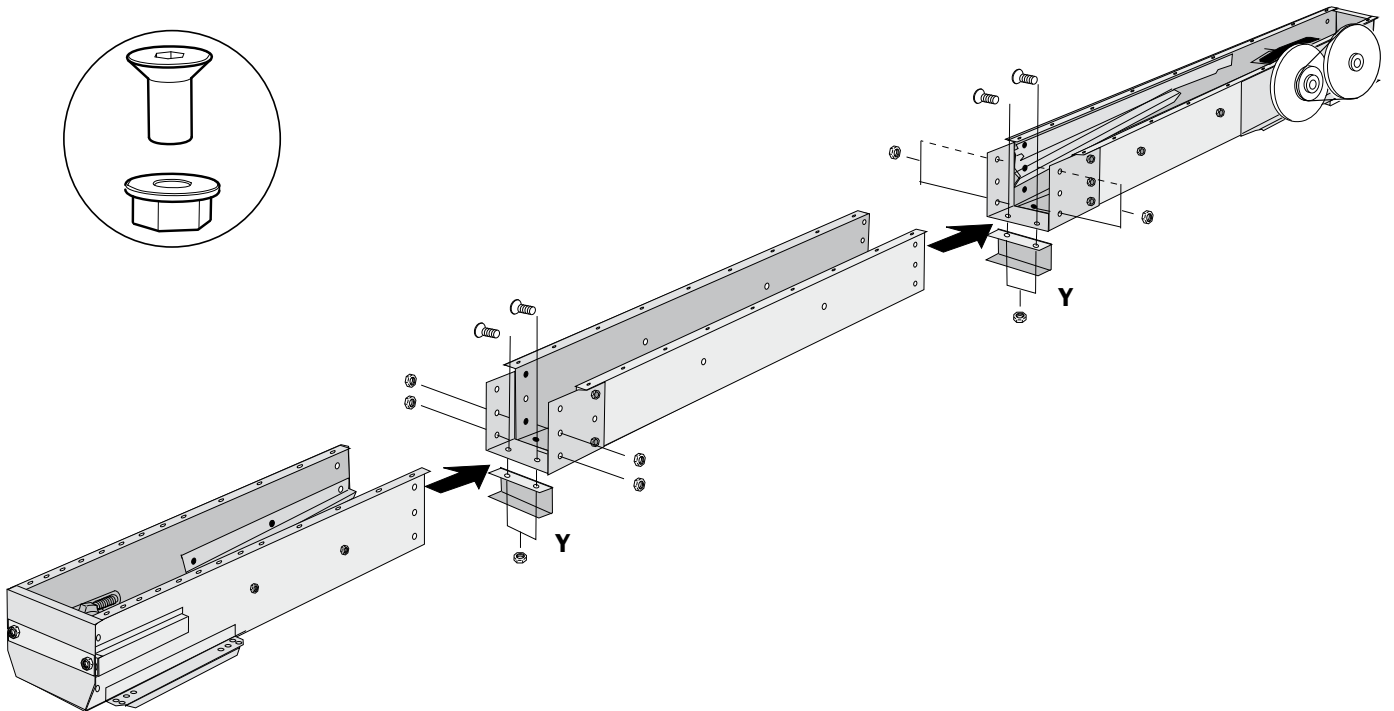

4.  
Assemble the lengths of chain into one long conveyor chain.

**⚠ IMPORTANT!**

Distribute any lengths of brush flight/bucket flight evenly along the conveyor chain.

5.  
Fit the conveyor chain in place in the bottom of the conveyor.

NB! The chain brackets "push" the flights against the drive.

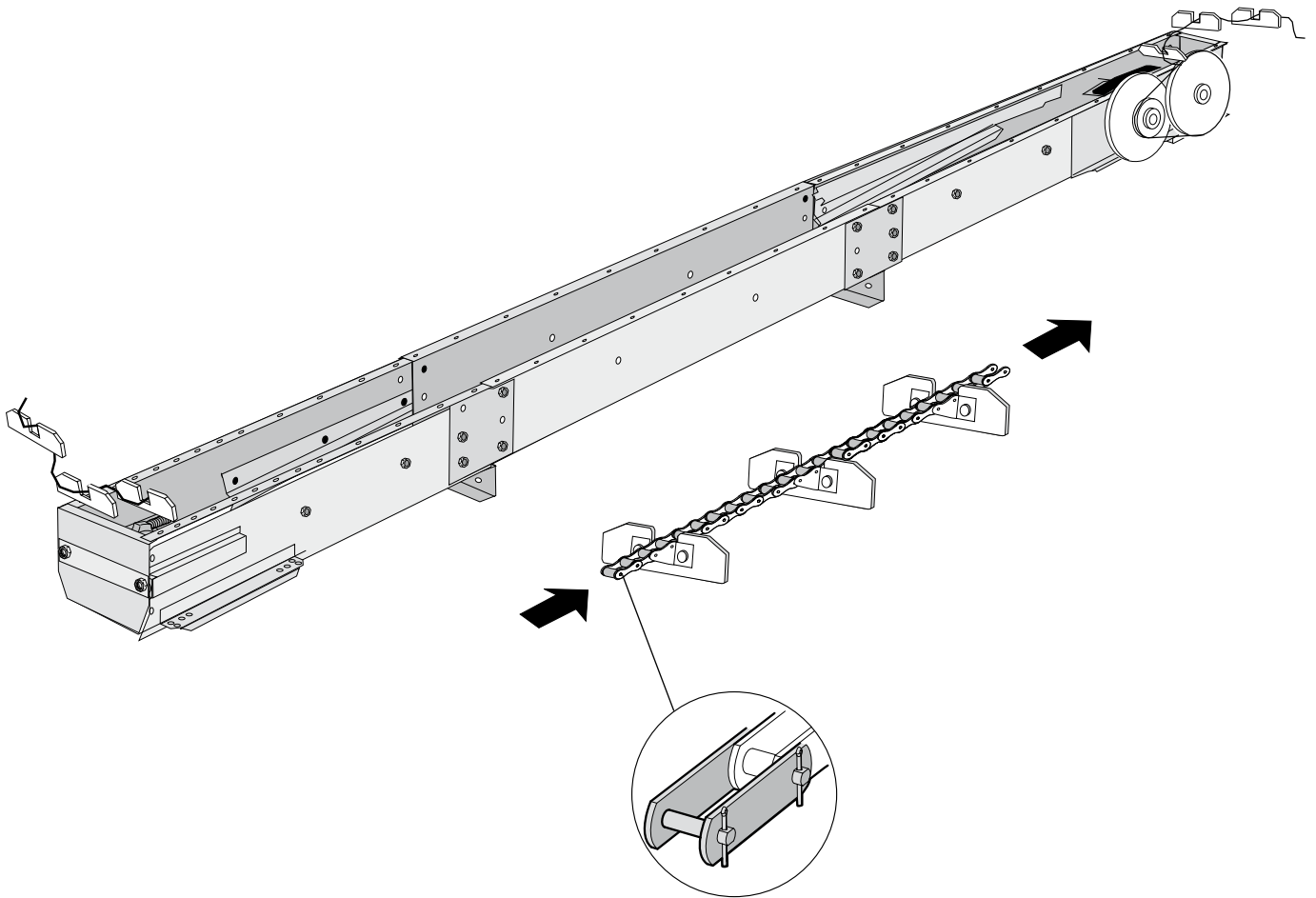

6.

Fit the guide rails/intermediate trays from the drive to the tail end.



**IMPORTANT!**

Fit the finger joints together correctly.

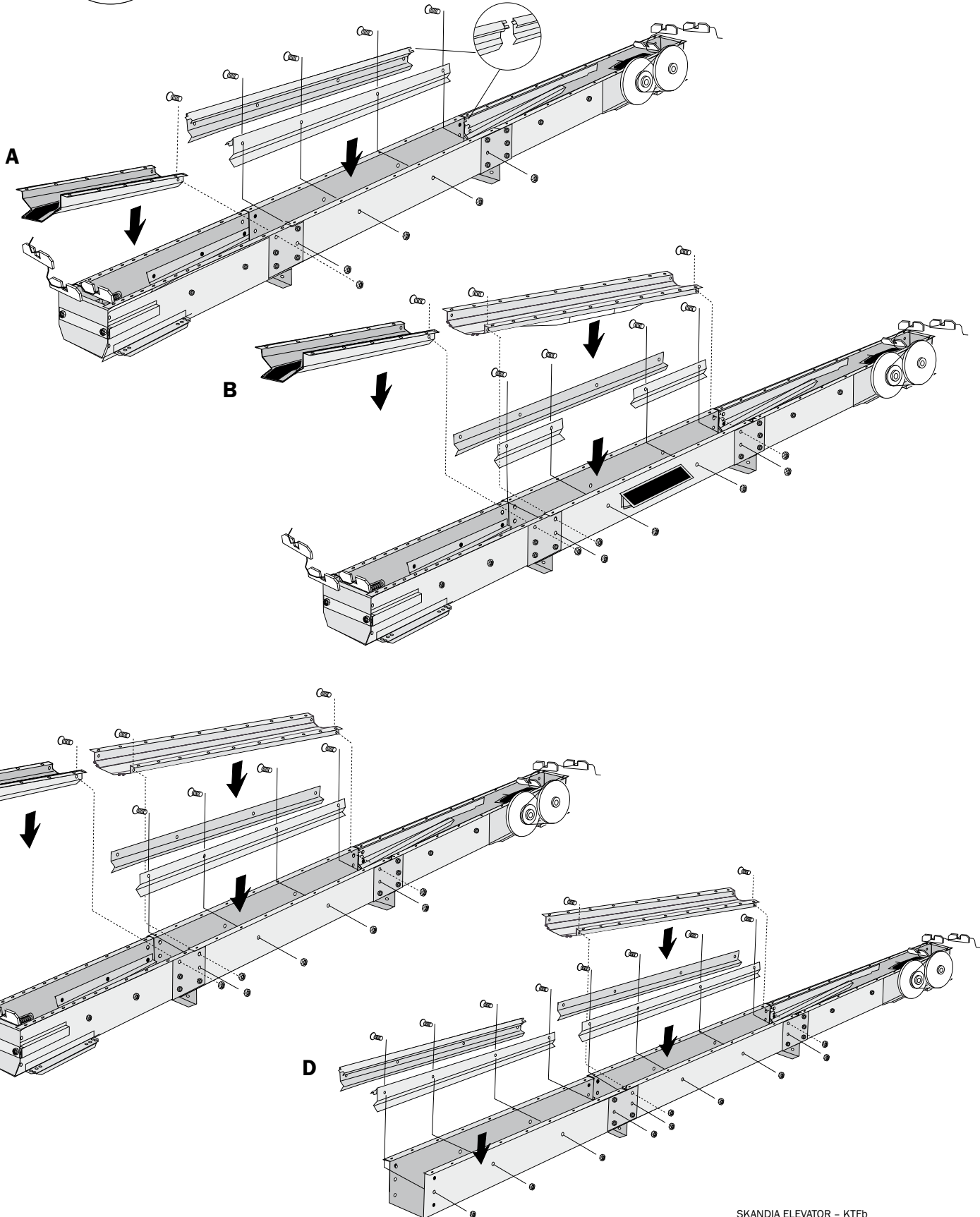
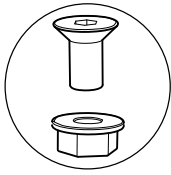

7.

Lay the rest of the conveyor chain on the upper level.

8.

Slide the tail end shaft to forward position, towards the drive.

Position the conveyor chain over the tail end's chain sprocket. Shorten it if necessary to the correct length and then assemble it.

**⚠ IMPORTANT!**

Ensure the conveyor chain is centred, runs freely and does not foul the sides of the conveyor.

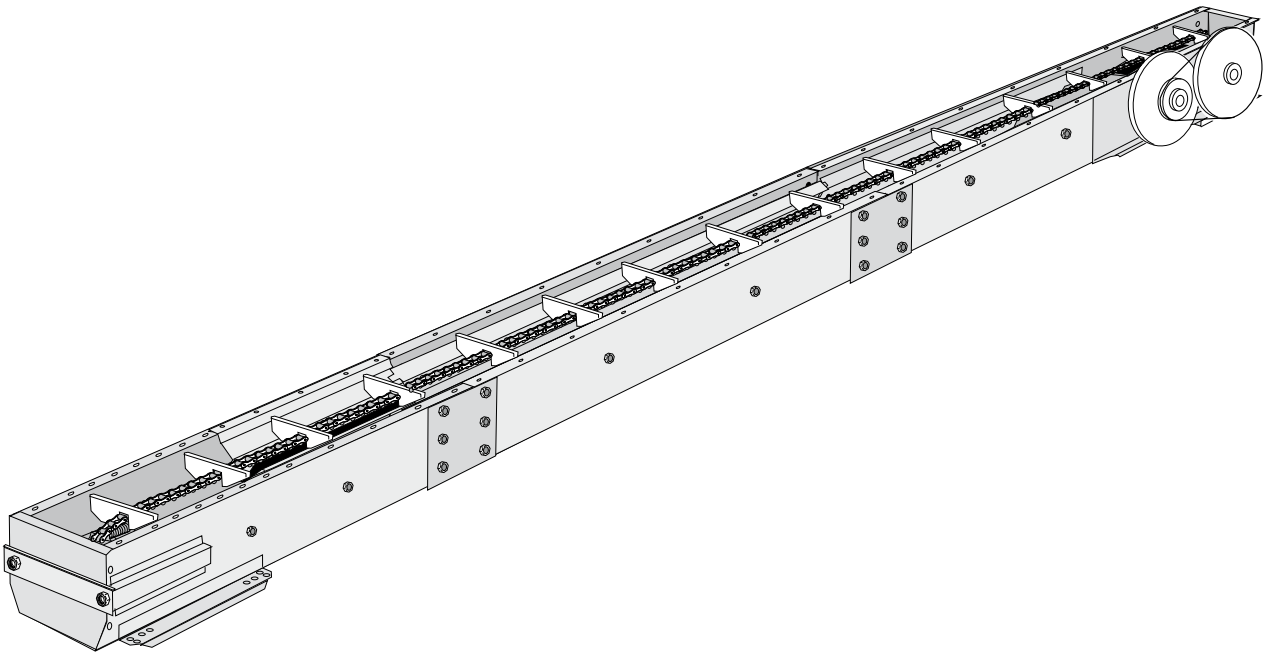

9.

Tighten the conveyor chain with the tensioning bolts in the tail end.

NB! The tensioning bolts have self-locking fixed nuts inside the conveyor.

**⚠ IMPORTANT!**

- Ensure the tail end shaft is at right angles to the conveyor chain.
- Ensure the conveyor chain is not tensioned too much. The conveyor chain is too taut if it cannot be pulled sideways at the tail end shaft. Release the tension until it can be pulled slightly sideways.

Once assembly of the conveyor is complete, test run it for a while and then check the tension once again.

A new conveyor chain must be run for a period and then readjusted.

**⚠ IMPORTANT!**

Check the conveyor chain after 50 operating hours. See separate maintenance instructions for information on maintenance.

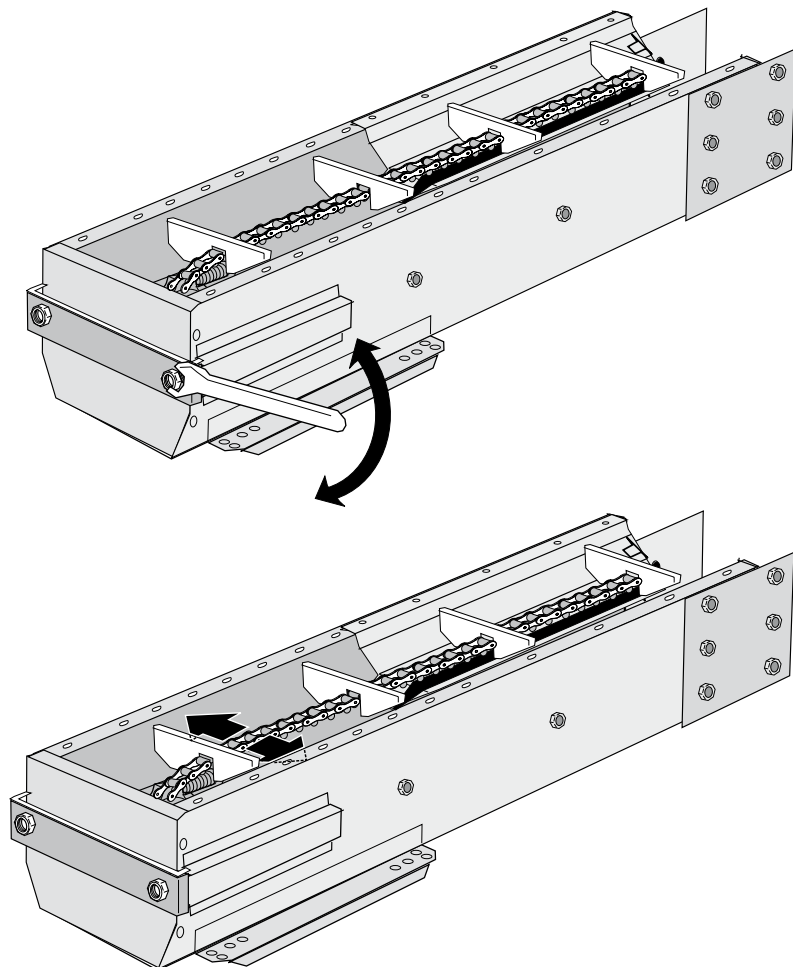



10.

NB! Fit inlet/outlet with existing bolts.

NB! Lid plates may not be used or will need to be cut to new lengths where inlets/raised lids are located.

11.

Stagger the lids when fitting.

**⚠ IMPORTANT!**

Fit a raised lid displaced 400 mm towards the tail end.

If an intermediate section with raised lid is to be assembled directly to the tail end, the tail end must also be of the raised lid type.

NB! Use the joining plate to cover joints in the lid that do not overlap.

**⚠ IMPORTANT!**

- Fit rubber mouldings in the joint grooves.
- When assembling outdoors, the joints in the side plates, lid and inlet must be sealed with silicone.

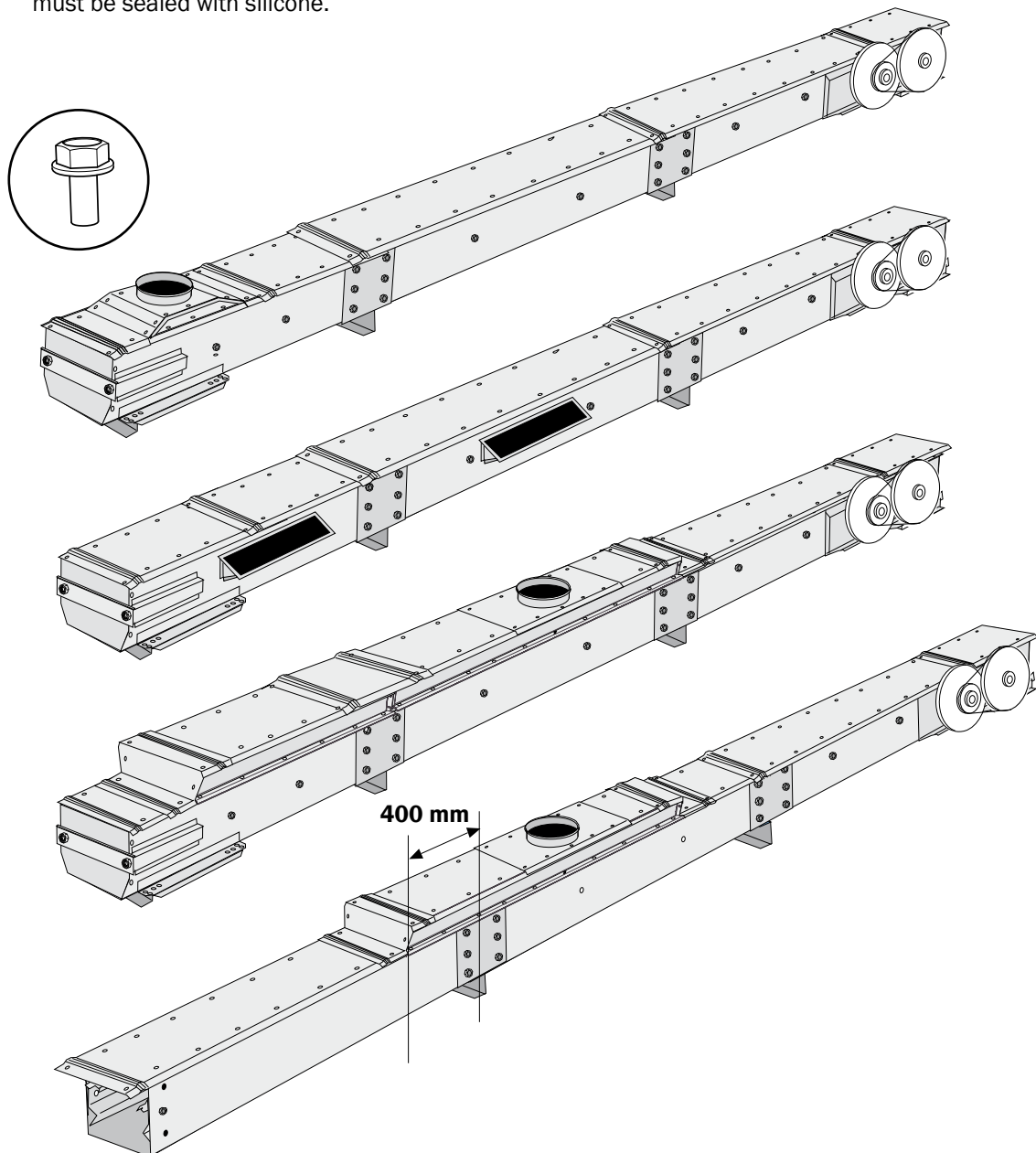

14.

**⚠ WARNING!**

The rotating drive shaft is partially exposed between the gearbox motor and the machine if the weather cover is not used on machines with gearbox motors.

15.

Pop up overloading flap (A) with safety switch is an optional accessory that stops the conveyor if it is overloaded or when the pop up overloading flap is opened.

**⚠ WARNING!**

- Connections to, from and between machinery must be permanently mounted and fully enclosed. If the design of the installation does not allow this at an outlet, finish off with a 1 m pipe.
- All electrical equipment is to be connected by a qualified electrician. See separate connecting directions for electronics.

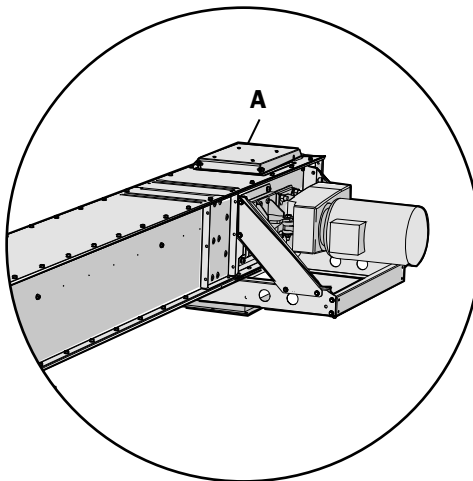



 **WARNING!**

- The motor must be installed by a qualified electrician.
- The power switch must be permanently mounted and located to allow easy access when carrying out maintenance work.
- Ensure the transmission guard is fitted during operation.

 **IMPORTANT!**

- Ensure the motor protection is set to the correct ampere setting for the motor.
- If the machine is being assembled outdoors, the motors and transmissions must be fitted with a weather cover.

1.  
Assemble components (A-C) with the same bolt.
2.  
Fit the motor and transmission chain.
3.  
Tighten the motor bridge (C) by hand and secure it.

 **IMPORTANT!**

Adjust the tightness of the transmission chains continuously. For more information concerning the transmission chain, see separate maintenance instructions.

4.  
The transmission guard (D) is hooked on at the bottom and fastened with two bolts at the top.

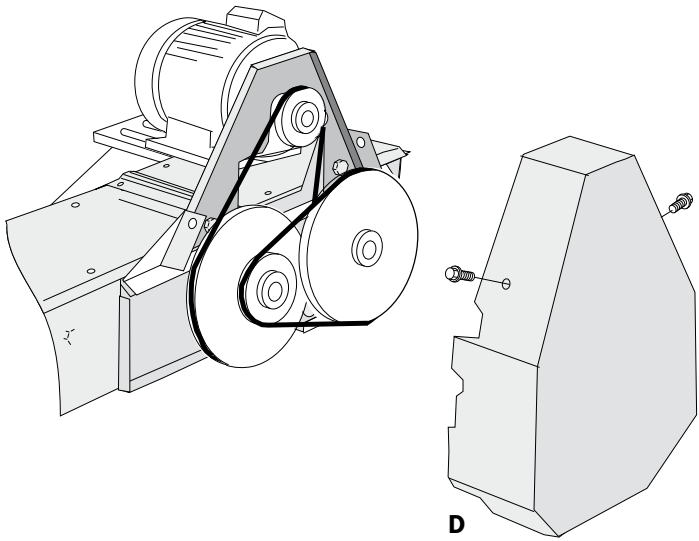
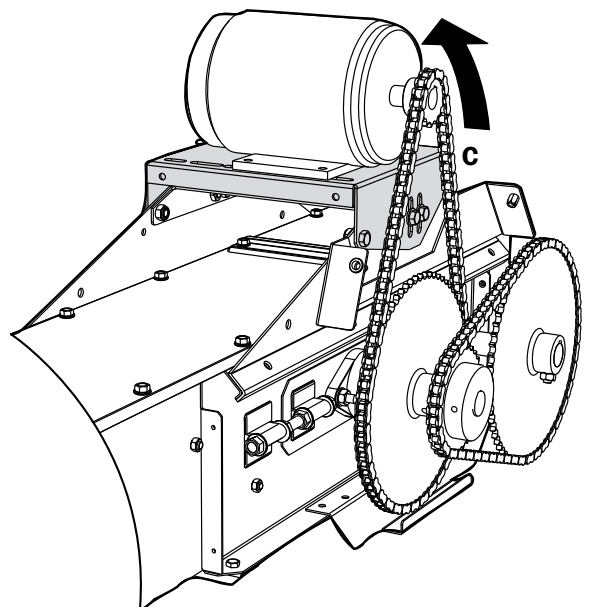
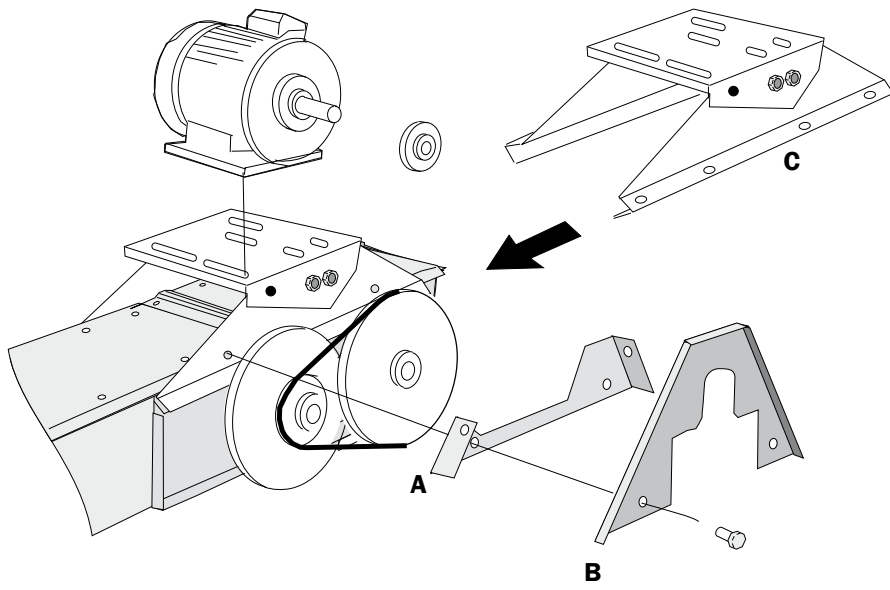



**SKANDIA ELEVATOR AB**

KEDUMSVÄGEN 14, ARENTORP  
S-534 94 VARA, SWEDEN

PHONE +46 (0)512 79 70 00  
FAX +46 (0)512 134 00

INFO@SKANDIA-ELEVATOR.SE  
WWW.SKANDIA-ELEVATOR.SE