

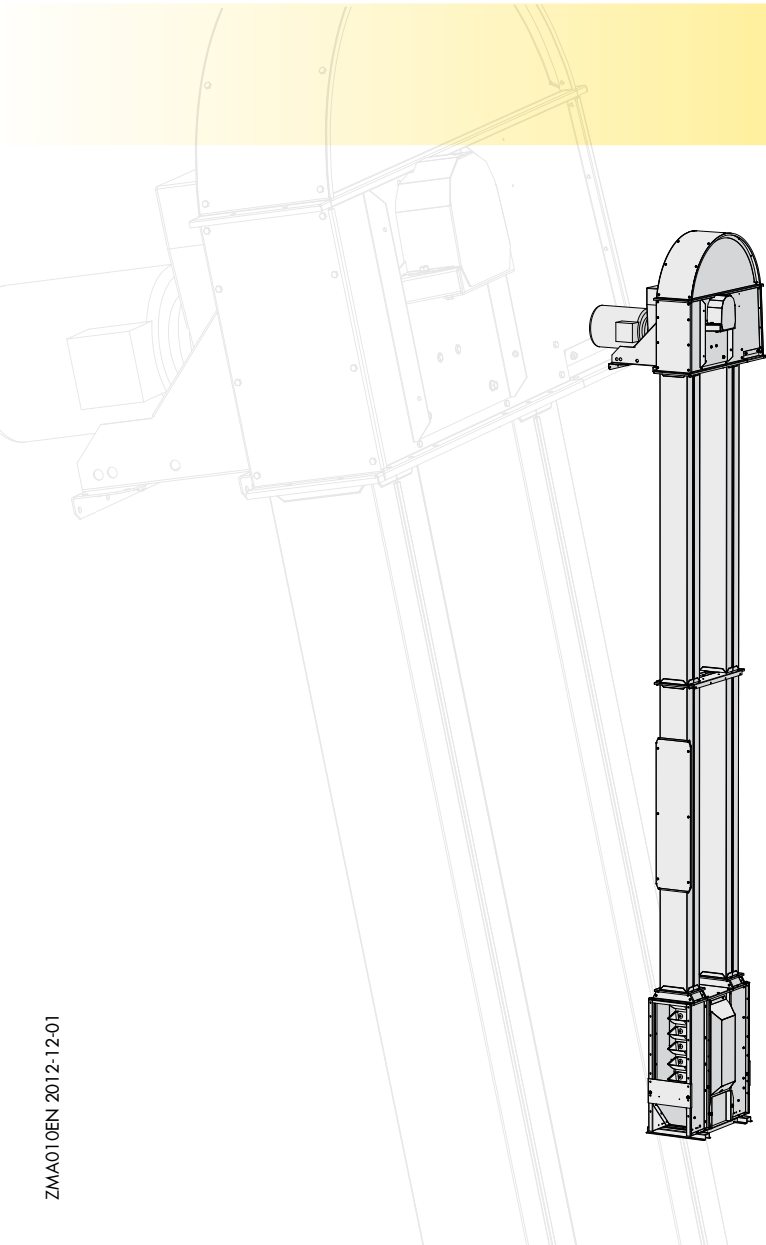

**SE**





## Goods inspection

Check that the number of packages agrees with the delivery note and that the packing and goods are not damaged. Make a note of any damage and missing materials on the consignment note and report it to the carrier and to us. Make sure the delivery is complete after unpacking the goods. Any materials that are found to be incorrect must not be assembled.

## Warranty

A 2-year factory warranty from the day of delivery applies to all models of Skandia Elevator AB machinery. A condition of the warranty and any subsequent compensation is that Skandia Elevator AB is contacted and an agreement reached between the customer and Skandia Elevator AB on how any faults should be rectified. The warranty covers all parts that are damaged or break due to faulty design or manufacture. Faults and damage caused by faulty assembly, incorrect use or lack of maintenance will not be covered by the warranty.

## CE mark

A CE mark is located on the transmission side of the elevator head and is proof that the machine has been manufactured in accordance with EU machine directives and complies with safety requirements. The CE mark contains information concerning year of manufacture, model designation and order number. Always specify the order number in the event of a claim and on orders for spare parts.

## EC Declaration

Skandia Elevator AB  
Arentorp  
S-53494 Vara  
SWEDEN

declare under our sole responsibility that the product:

**SE**

order number:

.....

to which this declaration relates is in conformity with Council Directive of 29 December 2009 on the harmonisation of the member States relating to machinery, 2006/42/EC.

Unless otherwise specified on the CE mark, the product is manufactured in accordance with EU Machinery Directive and is classified as Category II 3D/OD. It is intended for the transport of materials that correspond with ATEX Zone 22 and the external environment is unclassified.

Vara 29/12 2009

Joakim Larsson, CEO



## Thank you for choosing Skandia Elevator!

Your conveyor system must be assembled correctly and maintained thoroughly if it is to operate satisfactorily. These assembly instructions and the separate maintenance instructions must be followed for the warranty to apply.

We hope you will be pleased with your Skandia conveyor equipment for a long time.

<b>Machine overview</b> .....	<b>6</b>
<b>Safety information</b> .....	<b>7</b>
General safety information.....	7
Electrical safety.....	8
Safety decals.....	9
<b>Before assembly</b> .....	<b>11</b>
<b>Connection of the machine</b> .....	<b>12</b>
Location of inlet.....	12
Connecting another machine to the elevator.....	13
Connecting the intake pit to the elevator.....	13
Connecting the elevator to the conveyor.....	13
<b>Assembling the machine</b> .....	<b>15</b>
Belt alignment switch.....	15
Elevator legs.....	16
Elevator head.....	17
Back stop.....	19
Bucket belt.....	20
Buckets.....	21
Centring of bucket belt.....	22
Adjusting the splash guard.....	23
Elevator hood.....	24
Speed monitor.....	25
Explosion relief panels.....	25
Inlet.....	26
Water seal.....	26
Inlet slide.....	27

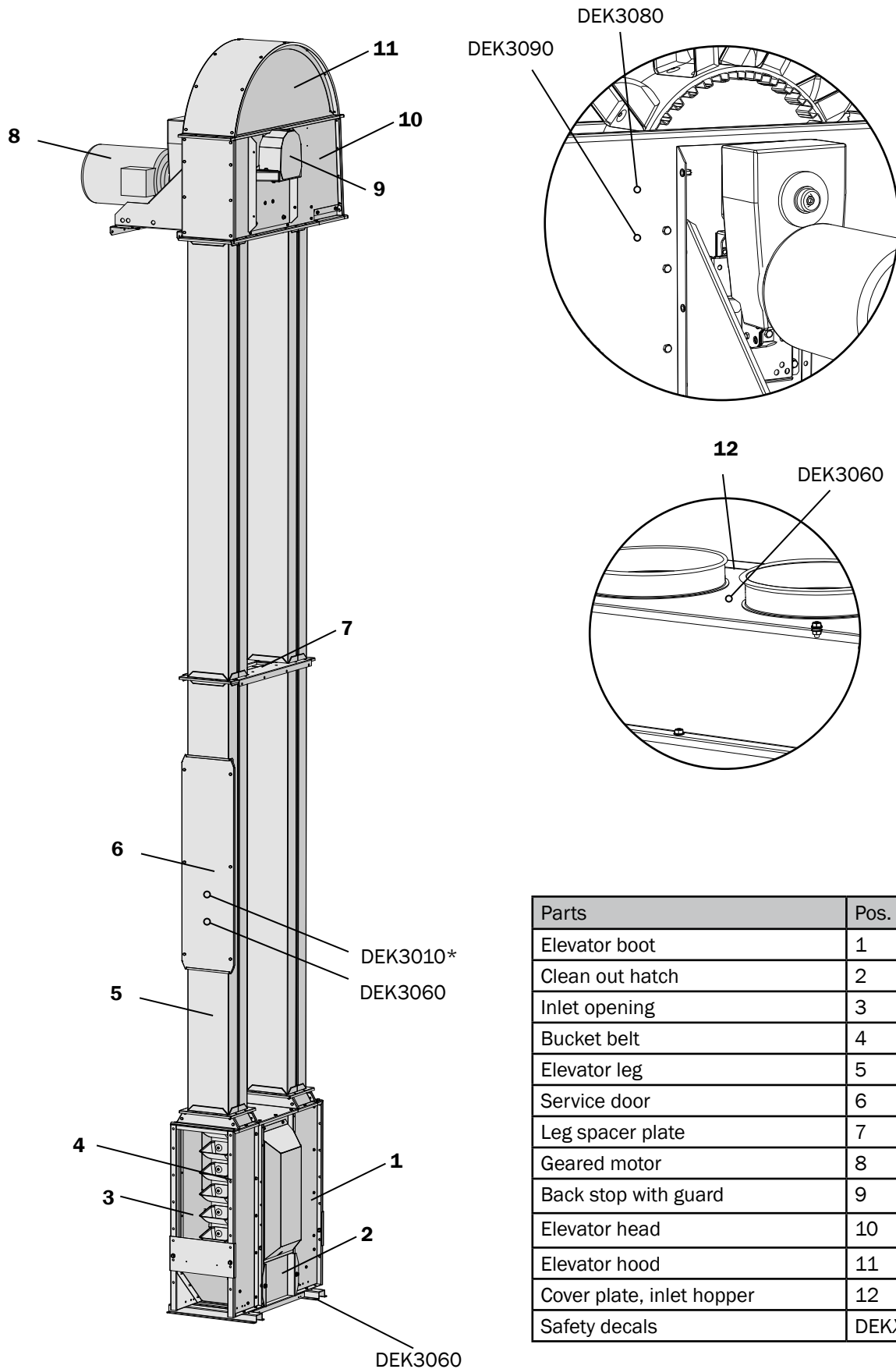

Parts	Pos.
Elevator boot	1
Clean out hatch	2
Inlet opening	3
Bucket belt	4
Elevator leg	5
Service door	6
Leg spacer plate	7
Geared motor	8
Back stop with guard	9
Elevator head	10
Elevator hood	11
Cover plate, inlet hopper	12
Safety decals	DEKXXXX

The owner of the transport equipment is responsible for these assembly instructions always being available to the fitters, electricians, maintenance technicians and engineering technicians concerned.

Incorrect assembly and/or operation may lead to personal injury or damage to the conveyor equipment and/or other equipment. It can also cause malfunctions or a reduction in capacity.

Read the assembly instructions carefully before assembly, electrical connection, maintenance or operation commences. If any part of these instructions should be difficult to comprehend, please get in touch with your reseller for assistance.

The safety information is presented and interpreted as follows:

**⚠ WARNING!**

Disregarding instructions given in warnings can cause serious personal injury or death.

**⚠ IMPORTANT!**

Ignoring the instructions given in important texts may cause damage to the conveyor equipment and/or other equipment. It can also cause malfunctions or a reduction in capacity.

NB! indicates that the text contains information that will simplify the assembly process.

## General

**⚠ WARNING!**

- Ensure that everyone responsible for assembly, electrical connection, maintenance and operation of the conveyor equipment has read and understood the instructions and safety information.
- Use protective gloves, helmet, steel-toed boots, ear defenders, protective goggles and high-vis vest when carrying out assembly, electrical connection, maintenance and operation of conveyor equipment.



### **WARNING!**

- Stop the machinery and turn off electric power before attempting any type of assembly, electrical connection or maintenance work.
- Do not start the machinery without the elevator hood and all hatches, covers, lids and guards fitted in such a way they can only be opened with tools.
- Connections to, from and between machinery must be permanently mounted and fully enclosed. If the design of the installation does not allow this at an outlet, finish off with a 1 m pipe.

### **IMPORTANT!**

- If the machine is being assembled outdoors, the motors and transmissions must be fitted with a weather cover.
- If a short circuit should occur, ensure that the electrical equipment is in working order before continuing operation.
- Ensure that the electrical equipment is kept free from dirt, dust, moisture and electrostatic charge.

## Electrical connection

Incorrect electrical connection may lead to personal injury or damage to the conveyor equipment and/or other equipment. It can also cause malfunctions or a reduction in capacity.

### **WARNING!**

- All electrical equipment is to be connected by a qualified electrician. See separate connecting directions for electronics.
- The power switch must be permanently mounted and located to allow easy access when carrying out maintenance work.
- Ensure the speed monitor is engaged during operation.

### **IMPORTANT!**

- Ensure the motor protection is set to the correct ampere setting for the motor.
- Read the "Back stop" section in the elevator's assembly instructions before test starting the motor for the first time.
- Ensure all breakers for the belt alignment switch (optional extra) are engaged during operation.
- Ensure all switches for the explosion relief panels (optional accessory) are engaged during operation.

## Maintenance

Inadequate maintenance may lead to personal injury or damage to the conveyor equipment and/or other equipment. It can also cause malfunctions or a reduction in capacity.

### **WARNING!**

Read the separate maintenance instructions before taking the machine into service.



## Safety decals

### **WARNING!**

The machine is supplied with safety decals on delivery. They must not be removed or defaced. If a safety decal becomes damaged, you can order a new one free of charge from Skandia Elevator AB. Specify the part number of the decal. See the section below and the previous chapter Machine Overview.





#### There are safety decals for:





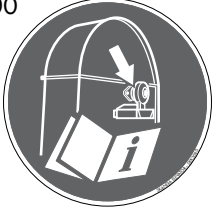

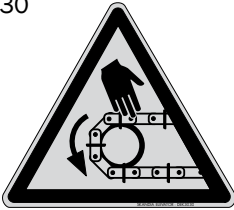

- Mandatory (white symbol on round blue background).
- Forbidden (black strike-through symbol on round white background with red surround).
- Warning (black symbol on triangular yellow background with black surround).

### **WARNING!**

The mandatory instruction, forbiddance or warning given on all safety decals must be considered or serious injury or death may follow.

Skandia Elevator machines have the following safety decals:

Part number/Safety decal Refer to the "Machine Overview" chapter for placement.	Written definition
DEK3090 	Read the "Back stop" section in the elevator's assembly instructions before test starting the motor for the first time.
DEK3100 	Do not place the valve with the motor side face down.
DEK3140 	Changing settings and equipment is prohibited.
DEK3030 	Warning for conveyor chain!
DEK3060 	Warning for bucket belt!

<p>DEK3040</p> 	<p>Warning for chain drive!</p>
<p>DEK3050</p> 	<p>Warning for belt drive!</p>
<p>DEK3070</p> 	<p>Warning for rotating conveyor drive shaft!</p>
<p>DEK3080</p> 	<p>Warning for rotating elevator drive shaft!</p>
<p>DEK3110</p> 	<p>Warning for moving machinery!</p>
<p>DEK3120</p> 	<p>Warning for moving machinery!</p>
<p>DEK3010</p> 	<p>Warning for dust explosion!</p>
<p>DEK3130</p> 	<p>Warning, a maximum of 2 people = 200 kg/440 lbs may be on the platform and ladders simultaneously!</p>

**⚠ IMPORTANT!**

- Ensure that an elevator with standard plate thickness used in the elevator legs is not built higher than permitted. Refer to the "Technical specifications" section in the separate "Maintenance instructions".
- If a platform is being mounted on the elevator, ensure that the plate thickness of the elevator legs is at least 1.25 mm.
- Sections can be assembled together to a maximum of 8 metres in length and then lifted into place. The weight must be distributed over several lifting points.
- The elevator is to be braced every 4 metres to a leg joint. The top brace can be to a support frame. Bracing must be carried out so that it can withstand the expected load.
- Ensure there is no risk of the elevator boot standing in water. Lift/raise it if necessary.

NB! Place the elevator boot so that the clean-out hatch (A) is easily accessible and planned connections can be made.

When feeding from one side only, remove rib plate (B) and fit cover plate (C) over the unused inlet.

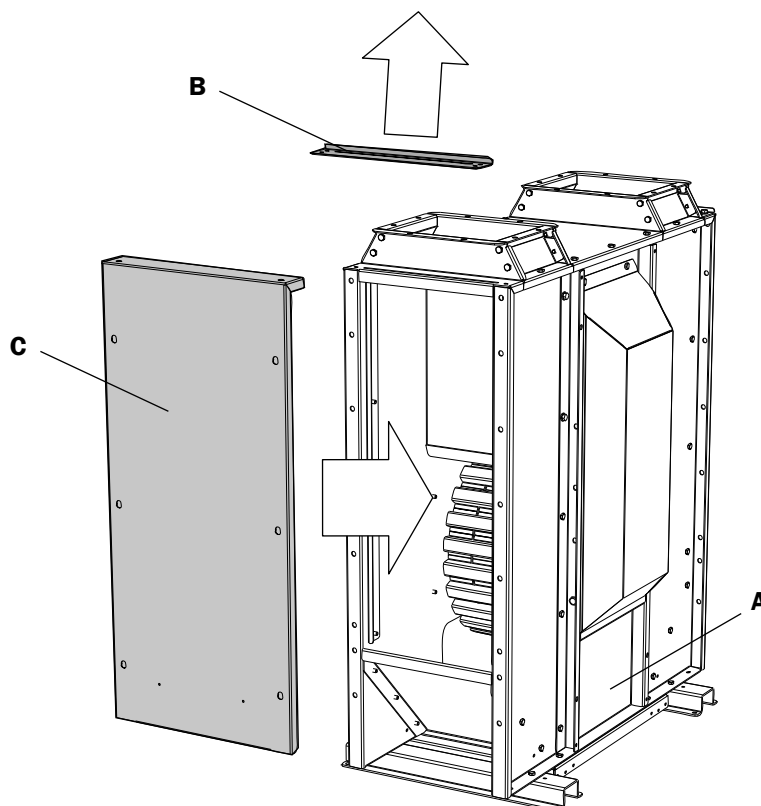

**⚠ IMPORTANT!**

Assemble the elevator level within specified tolerances (X and Y are vertical references and Z is a parallel reference).

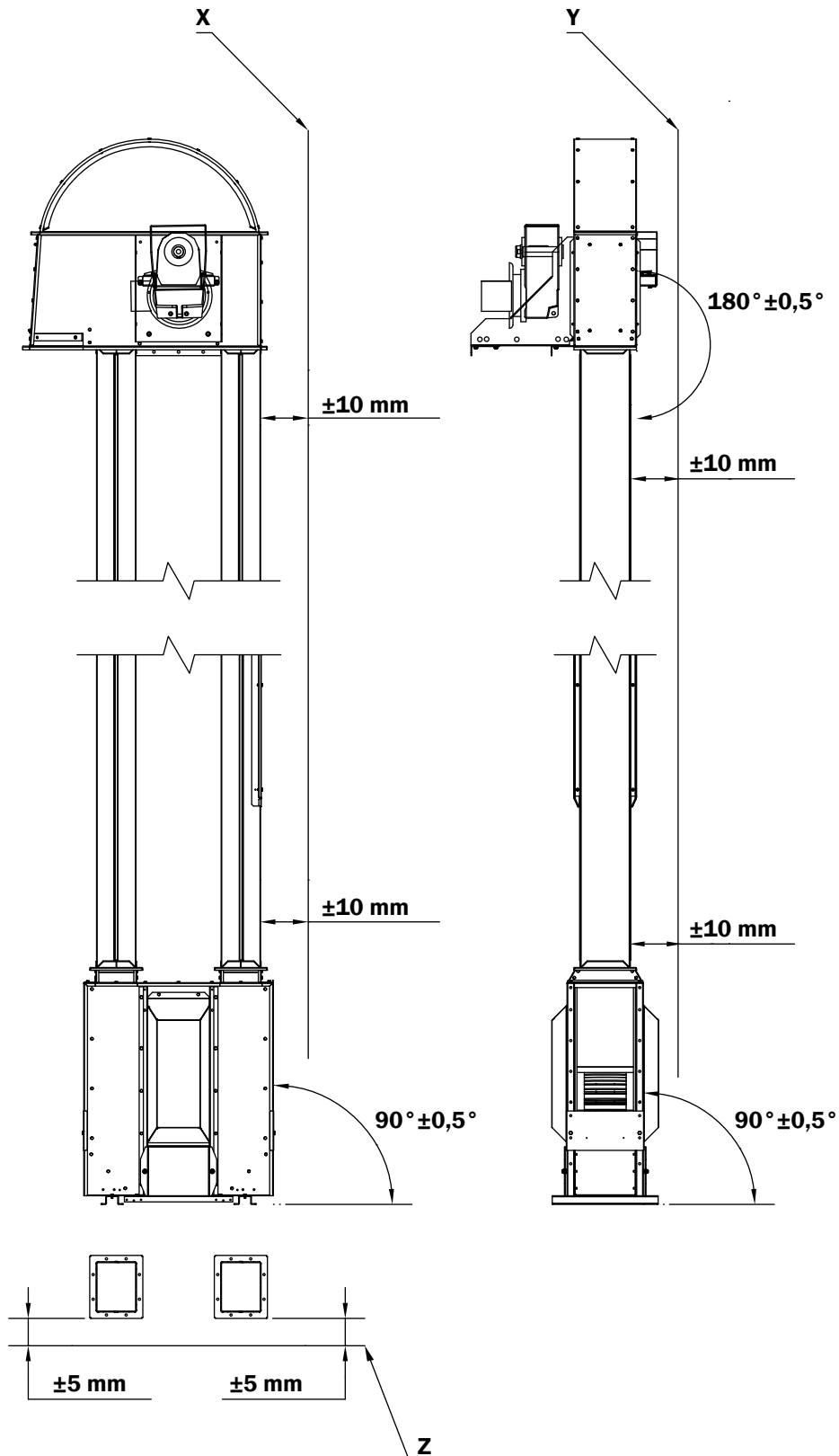

**⚠ IMPORTANT!**

- Mealy, light material and slow running material must always be fed on the descending leg side. Use only recommended inlet, outlet and connecting components.
- Ensure the ducting is dimensioned sufficiently and that its angle of inclination is at least 45°.

## Location of inlet

**⚠ WARNING!**

Unused inlets are to be sealed.

**⚠ IMPORTANT!**

- Assemble the inlet at the height shown in the illustration. The height varies for certain inlet types depending on whether it is located on the ascending or descending leg side.
- Always use the cover on the inlet hopper (A, B).

A. Inlet hopper

B. Extended inlet hopper

C. Connecting channel

D. Connecting hopper

E. 45° Inlet

NB! Inlet hopper (A) is designed for a descending leg side and extended inlet hopper (B) for an ascending leg side.

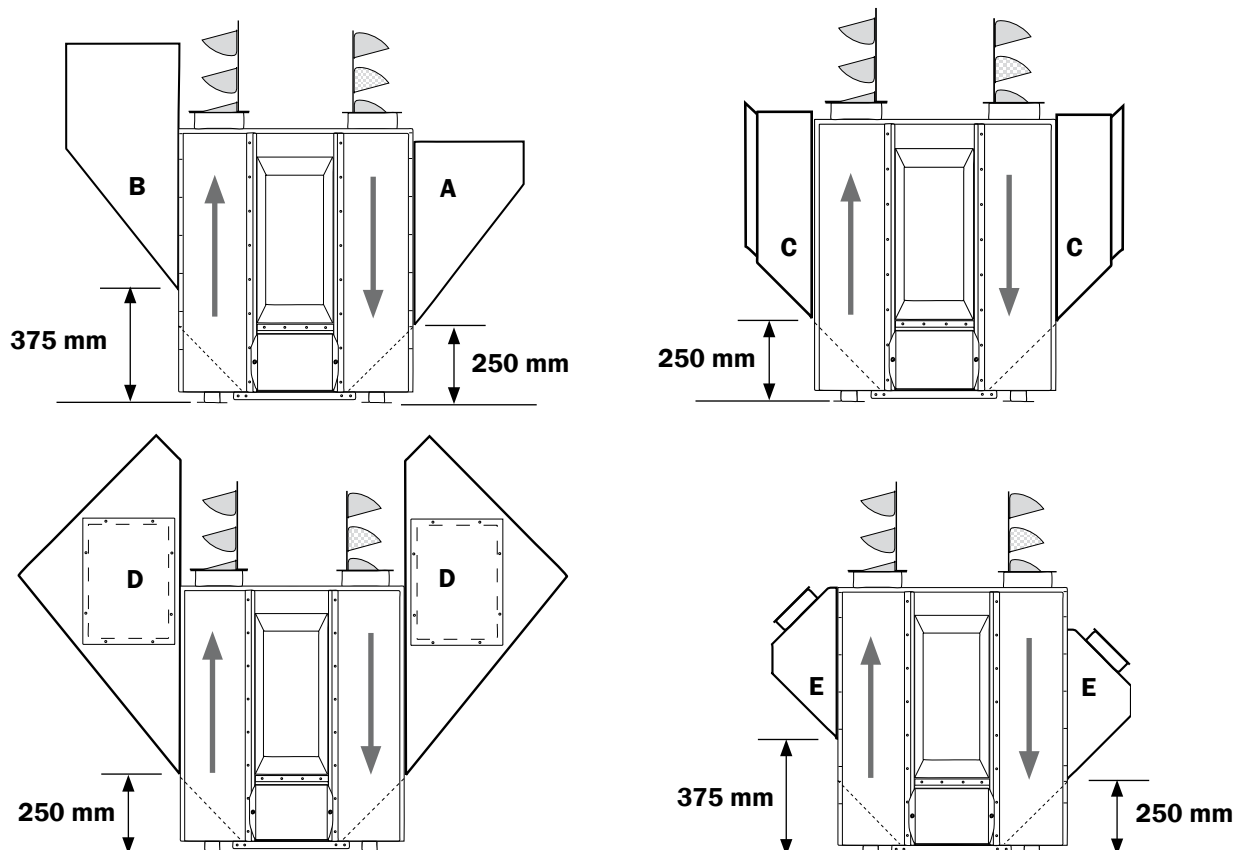

## Connecting another machine to the elevator



A conveyor or elevator can be connected to an elevator via inlet hopper (A, B), connecting hopper (D) or a 45° inlet (E).

## Connecting the intake pit to the elevator

### **IMPORTANT!**

If the elevator is to stand in an intake pit, connecting to the ascending leg side is recommended. An inlet regulator is always needed for this type of feeding.

If the intake pit directs the flow straight towards the bucket belt, the connection is to be done via a connecting channel (C).

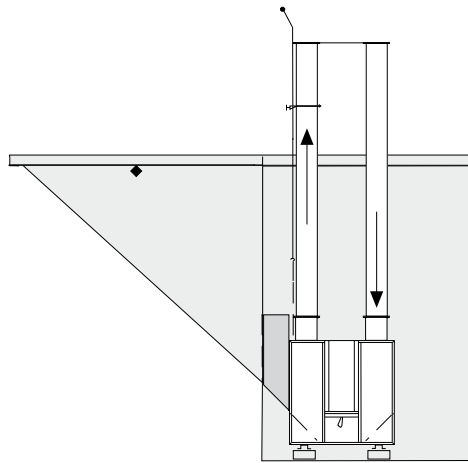

If the intake pit directs the flow 90° from the bucket belt, the connection is to be done via an extended inlet hopper (B).

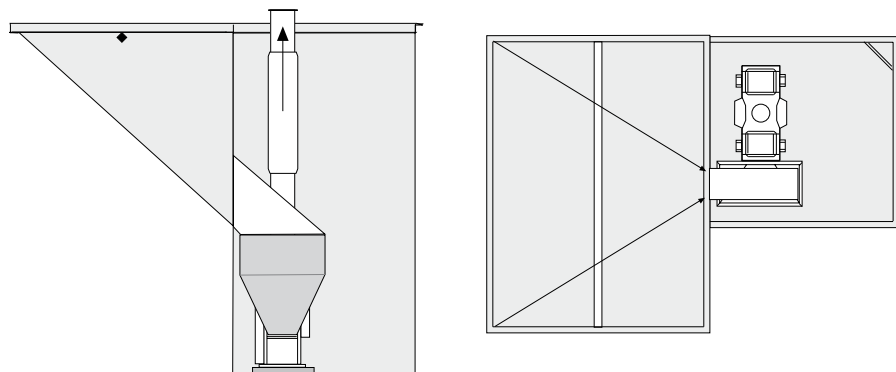

## Connecting the elevator to the conveyor

Connect the elevator to the conveyor according to the assembly instructions for the respective conveyor.

## Belt alignment switch

The belt alignment switch is an optional extra that stops the elevator if the bucket belt starts to foul on the slatted pulleys.

1. Mount the belt alignment switch (A) above the elevator boot on the descending leg side.
2. Fit a 0.25 m leg on the ascending leg side.

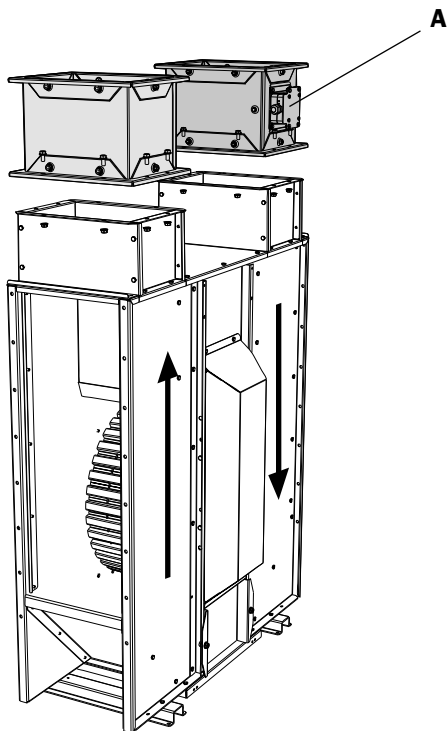

### **WARNING!**

All electrical equipment is to be connected by a qualified electrician.  
See separate connecting directions for electronics.

### **IMPORTANT!**

The belt must be able to move 10-15 mm to both sides without the belt alignment switch cutting the power.

## Elevator legs

### **IMPORTANT!**

- The top pair of legs must be at least 0.5 m long.
- The elevator is to be braced every 4 metres to a leg joint. The top brace can be to a support frame. Bracing must be carried out so that it can withstand the expected load.

NB! Fit the leg with the service door on the ascending leg side at ground level.

Fit the legs with a leg spacer plate in each joint.

NB! The legs have female and male joining pieces that are to be fitted together.

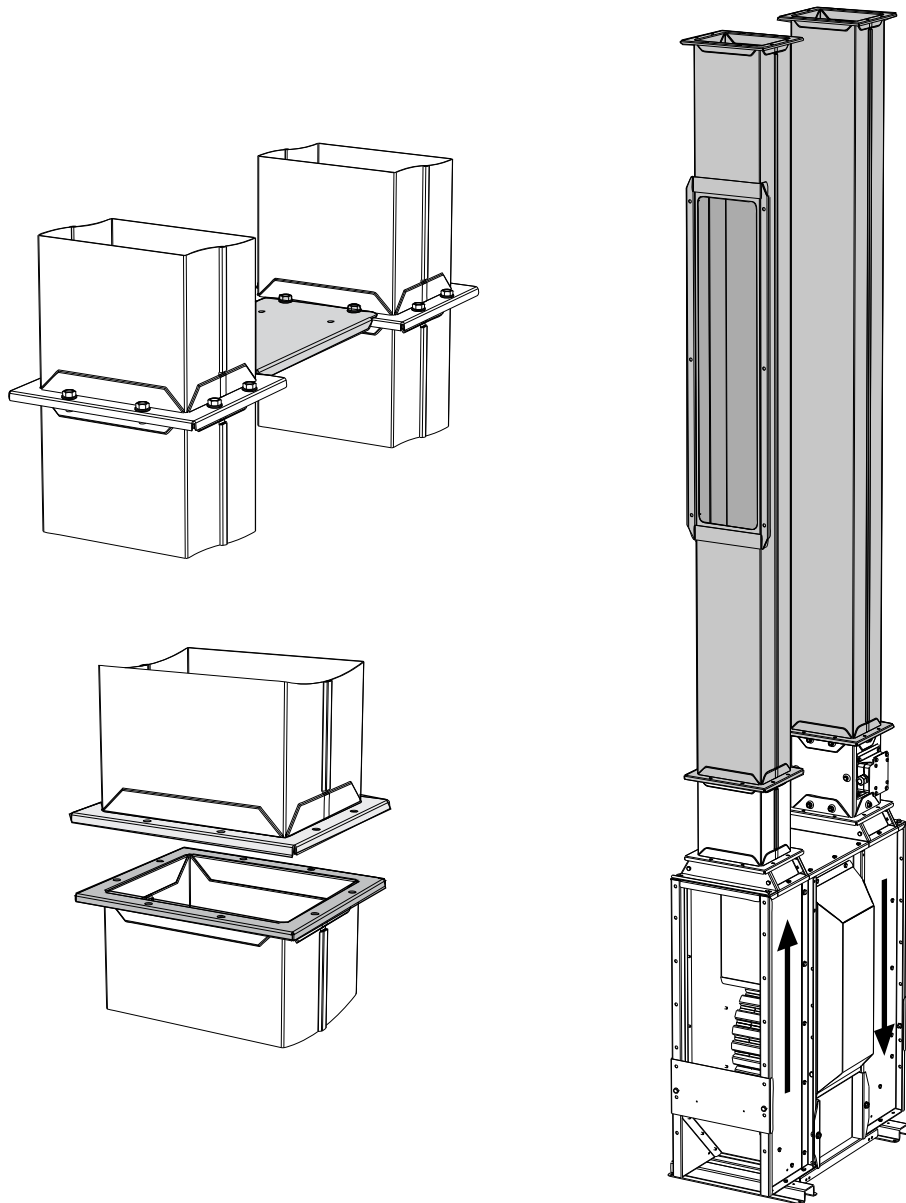



**⚠ IMPORTANT!**

If the legs are of the type assembled with bolt unions, the longitudinal joints (B) on the legs must be facing each other.

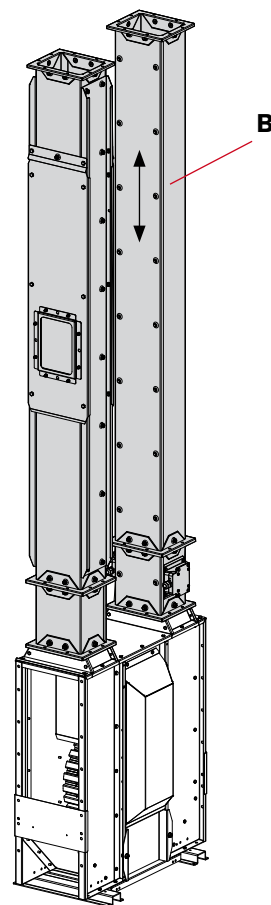

## Elevator head

Fit the elevator head.

**⚠ IMPORTANT!**

Relieve the weight of the elevator head with braces to the ground and/or a nearby stable construction. If the machine has a geared motor, brace its support frame. Never use the motor/geared motor to brace on.

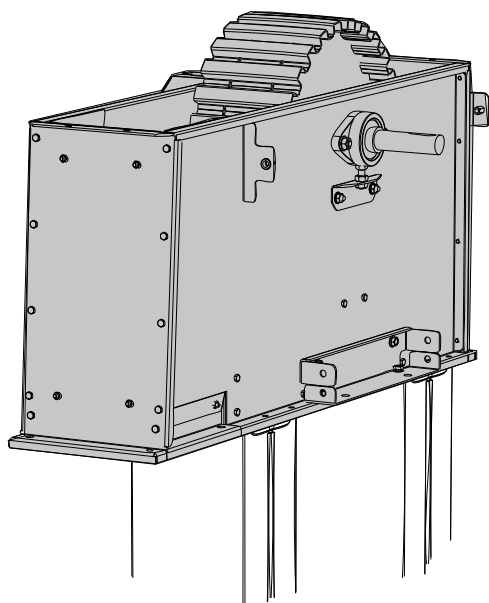

## Back stop

The back stop prevents the bucket belt reversing if the elevator stops during operation. It is mounted on the drive shaft protected behind a touch guard.

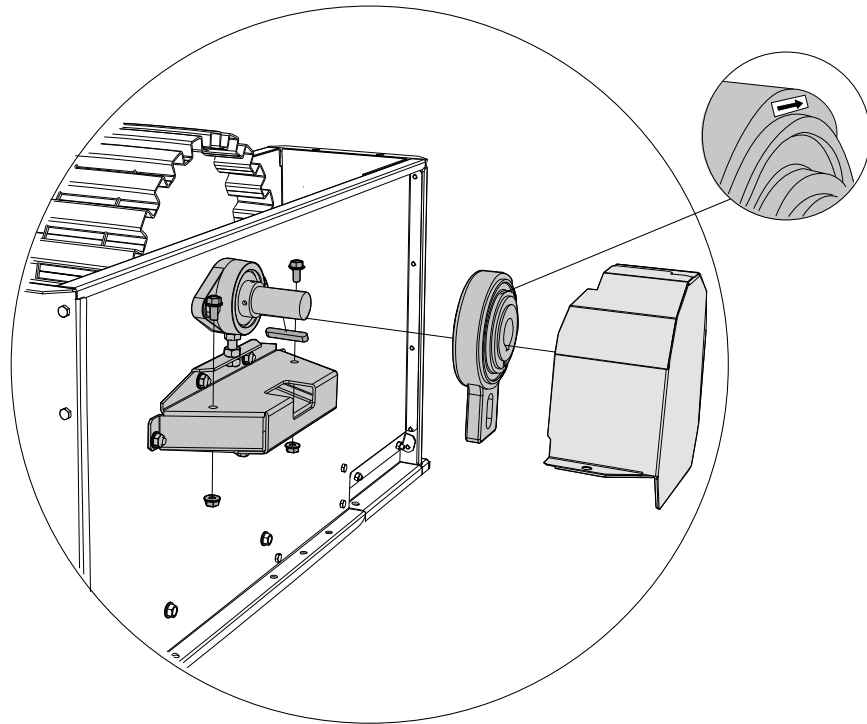

### **⚠ WARNING!**

Ensure the back stop and its touch guard are fitted at all times except during the start-up trial of the elevator. Detail (A) on the back stop must be assembled so that the side marked with the arrow is turned outward and the arrow pointing in the direction of travel.

### **⚠ IMPORTANT!**

- Remove the back stop from the drive shaft before the elevator is test started for the first time. Ensure that the bucket belt runs in the correct direction before refitting the back stop. The damage that can be caused to the back stop/geared motor by an incorrectly connected geared motor is not covered by the warranty.
- In the event of stoppage in operation, troubleshoot as described in the maintenance instructions and ensure the elevator boot is free of material before restarting.

## Bucket belt

### **WARNING!**

The bucket belt is always to be inserted/removed/tightened in situ using a vertical force or there is a risk of uneven loading and collapse of the legs.

1. Remove the service door and pull the bucket belt in place over the slatted pulleys so that the joins position themselves in the service opening.
2. Fasten the descending belt end to the front leg wall, just above the join, with a clamp.

### 3. **IMPORTANT!**

Cut the bucket belt so that the ends of the belt overlap at least 500 mm.

4. Cut off the ascending belt end about 15 mm above the centre of the first pair of holes and shape the end of the belt as illustrated.

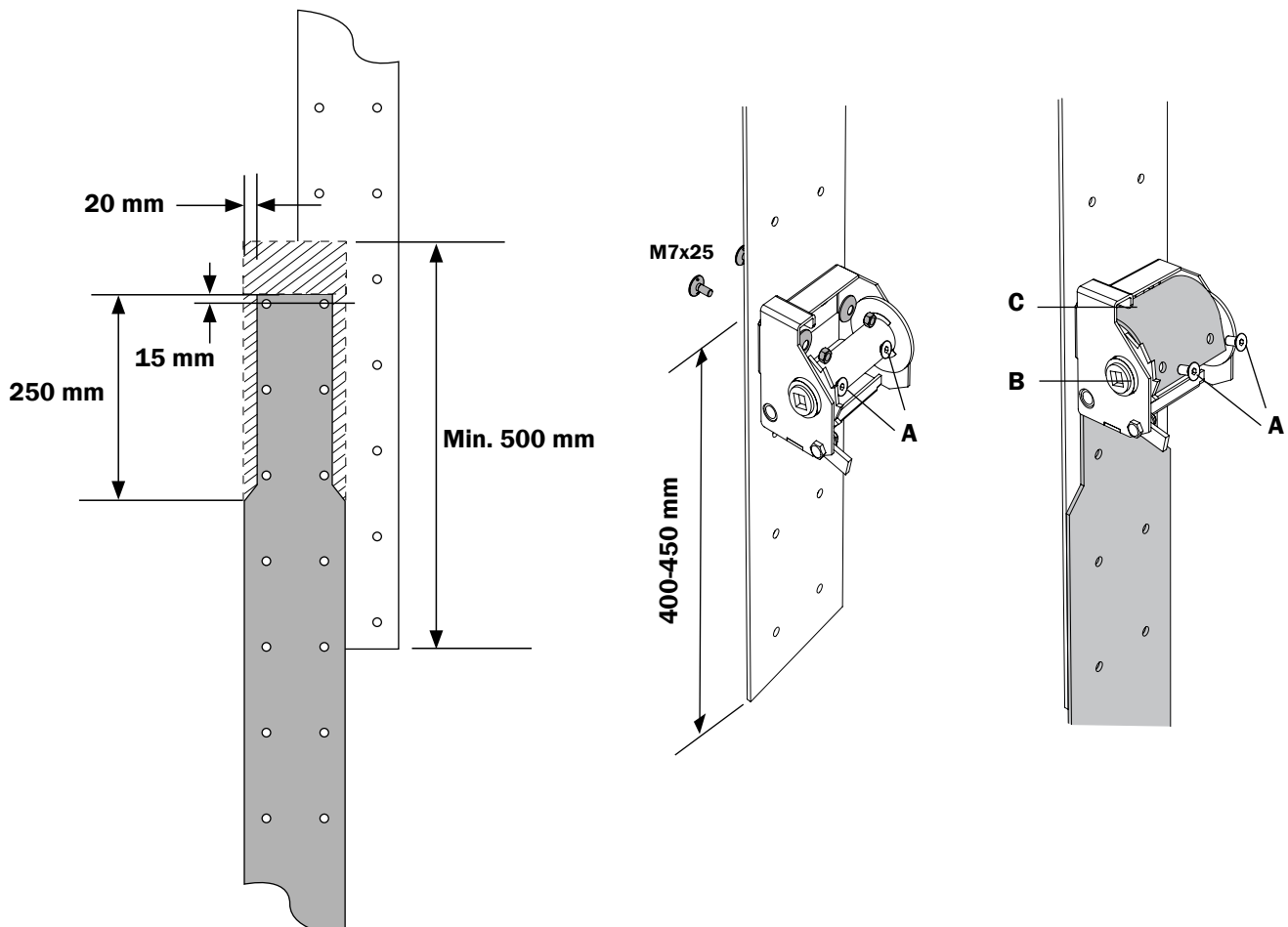

5.

Mount the belt tensioner about 400-450 mm up on the end of the belt pointing downward.

6.

Remove the bolts (A) from the belt tensioner. Put the shaped end of the belt behind the belt tensioner roller and assemble it at the front with the bolts (A).

7.

Roll up the bucket belt using a ratchet spanner in the tensioning pulley's square hole (B). Use a suitable tool in the pipe (C) for support. NB! The bucket belt is not finally tensioned until the buckets have been mounted.

8.

Mount the buckets as described below under "Buckets".

9.

After mounting the buckets, tension the bucket belt further as instructed above. Recommended torque for belt tensioning is specified in the section "Technical specifications" in the separate maintenance instructions.

10.

 **IMPORTANT!**

Join the ends of the belt by mounting 3 buckets where the ends overlap. Drill new holes through the ends of the belt if the existing holes are not aligned.

11.

Relieve the belt tensioner by releasing the ratchet one notch.

NB! The belt tensioner must remain mounted on the bucket belt when the elevator is in operation.

12.

 **IMPORTANT!**

Bucket belt tension must be checked and adjusted shortly after the elevator has been taken into service. Follow the description in the separate maintenance instructions.

## Buckets

### **WARNING!**

The buckets can have sharp edges.

NB! Do not mount buckets where the bucket belt overlaps until other buckets have been mounted and the bucket belt has been tensioned. See point 2.

NB! The bucket belt can only be drawn upwards as the back stop prevents it from going down.

1.

### **WARNING!**

The buckets are to be mounted so their weight is distributed evenly over the bucket belt during assembly.

Mount 10 buckets, one directly after the other, and then leave a space corresponding to 11 buckets. Repeat this around the belt.

Mount half the number of buckets on the next turn. Repeat turn after turn until all the buckets are mounted.

### **IMPORTANT!**

Fit washers as illustrated and tighten the nuts so much that bolt heads sink 1.5-2.5 mm into the bucket belt.

2.

Retighten the bucket belt as described in "Bucket belt" (9-12).

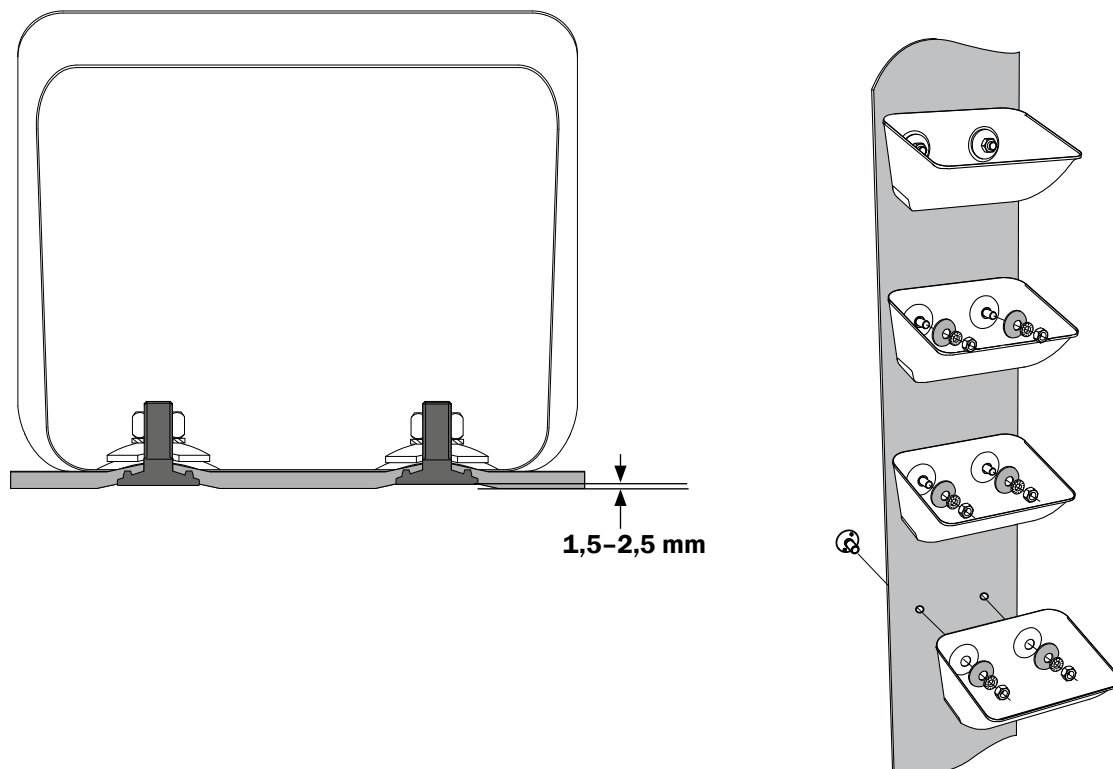

## Centring of bucket belt

### ⚠ **IMPORTANT!**

Ensure the bucket belt is centred on the slatted pulleys.

Check that the bucket belt is running on the slatted pulleys. If it gets twisted it must be adjusted.

### ⚠ **IMPORTANT!**

When adjusting the position of the bucket belt on the slatted pulleys, only lowering the drive shaft in the elevator head and raising the tail end shaft in the elevator boot is allowed. This is achieved by slackening the tension on each respective adjusting bolt (C/F).

#### **Example:**

Undo bolts (A) in the left-hand bearing if the bucket belt is running to the right of the slatted pulley in the elevator head. Lower the slatted pulley (B) by reducing the tension of the adjusting bolt (C) until the bucket belt runs in the centre. Retighten the bolts in the bearing.

Undo bolts (D) in the left-hand bearing if the bucket belt is running to the right of the slatted pulley in the elevator boot. Raise the slatted pulley (E) by reducing the tension of the adjusting bolt (F) until the bucket belt runs in the centre. Retighten the bolts in the bearing.

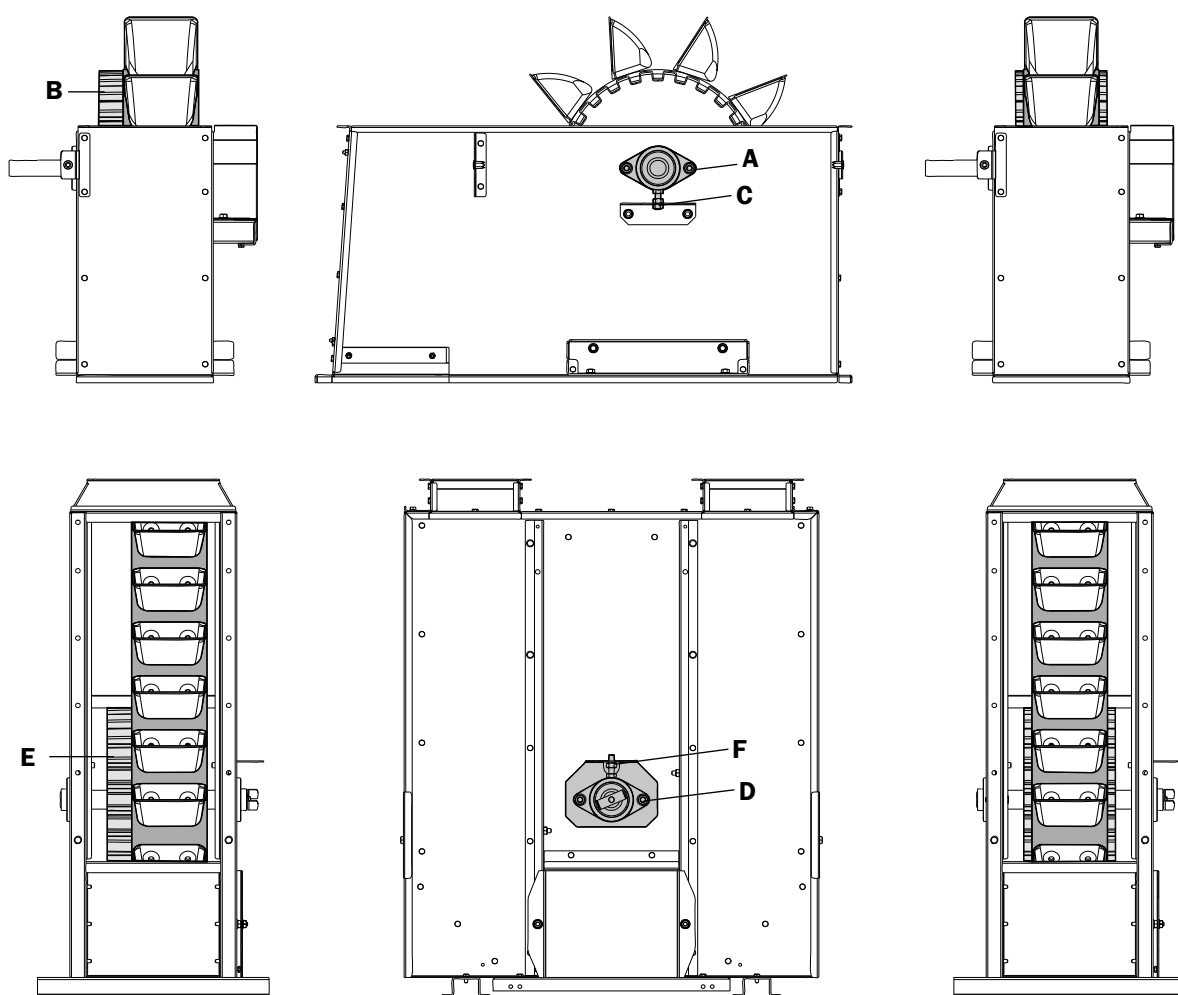

## Adjusting the splash guard

Set the distance of the splash guard (A) as illustrated.

### **IMPORTANT!**

The distance is measured to the bucket fitted over the seam where the belt ends are overlapping.

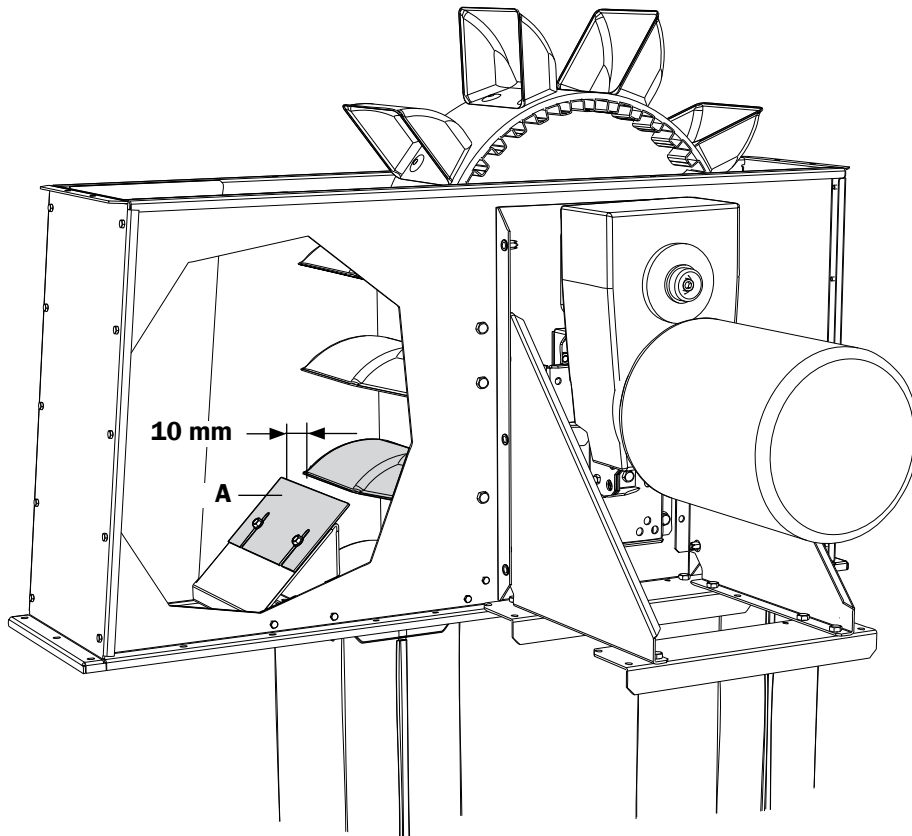

## Elevator hood

Lift in place the hood and fasten it.

If there is not enough room above the elevator head to lift in place the elevator hood, there are two alternative possibilities:

### Alt 1

Place the elevator hood between a pair of buckets on the ascending side and then pull it in place using the bucket belt. NB! If the elevator hood is to be removed, the bucket belt must be pulled round the other way, which is only possible if the back stop is removed. See "Back stop" in this section.

### Alt 2

Remove one of the elevator hood side plates and slide in place from the side.

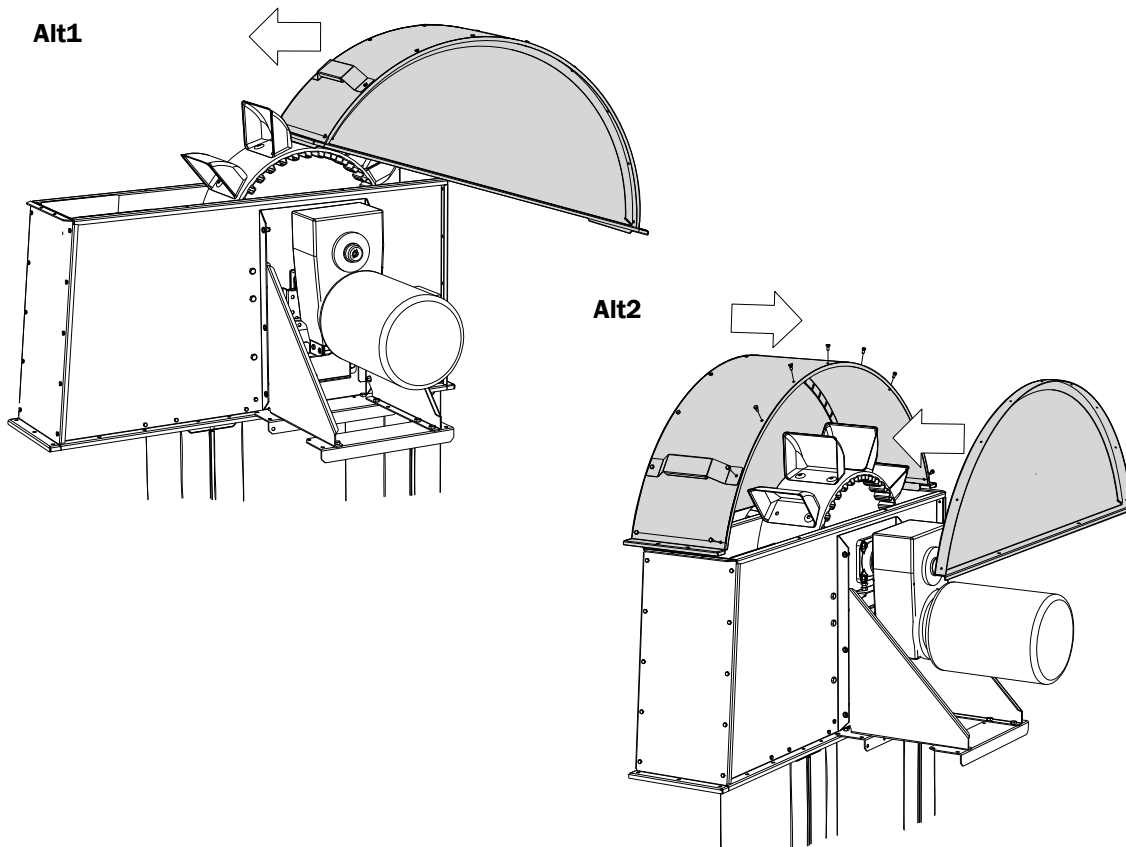

### **WARNING!**

The rotating drive shaft is partially exposed between the gearbox motor and the drive if the weather cover is not used.



## Speed monitor

The speed monitor stops the elevator if the bucket belt slips.

### **WARNING!**

- Ensure the speed monitor is engaged during operation.
- All electrical equipment is to be connected by a qualified electrician. See separate connecting directions for electronics.

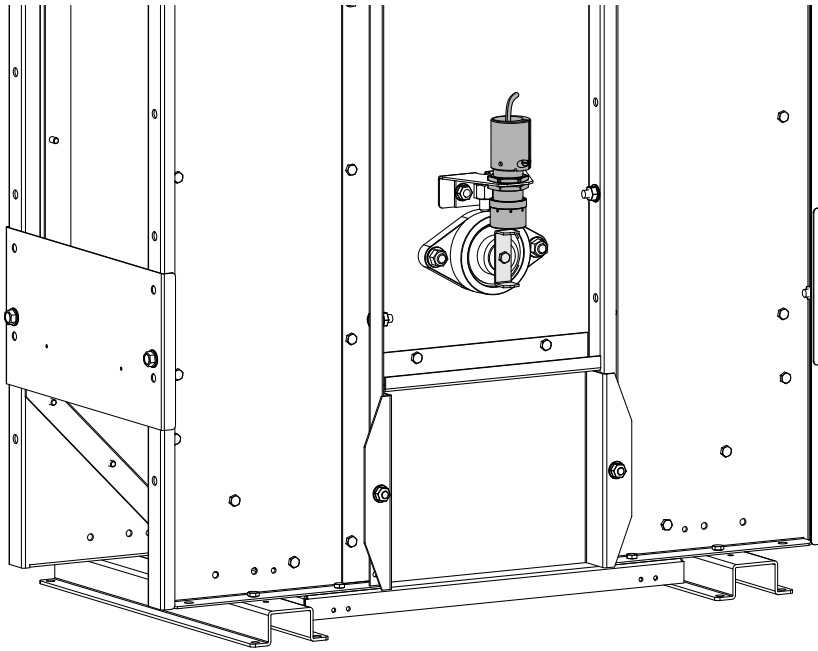

## Explosion relief panels

### **WARNING! & IMPORTANT!**

If the elevator is equipped with explosion relief panels, assemble them in the first pair of legs and then at a minimum of 6-meter intervals. Use only explosion relief panels supplied by Skandia Elevator.

### **WARNING!**

- Never stand in front of an explosion relief panel while the elevator is in operation.
- All electrical equipment is to be connected by a qualified electrician. See separate connecting directions for electronics.

## Inlet

Assemble the inlet at the height specified in the "Connection of the machine" section.

NB! Plate (A) at the bottom of the inlets is to be moved to the top when the inlet is fitted at the bottom. Temporarily remove the rib plate (B) in order to fit plate (A).

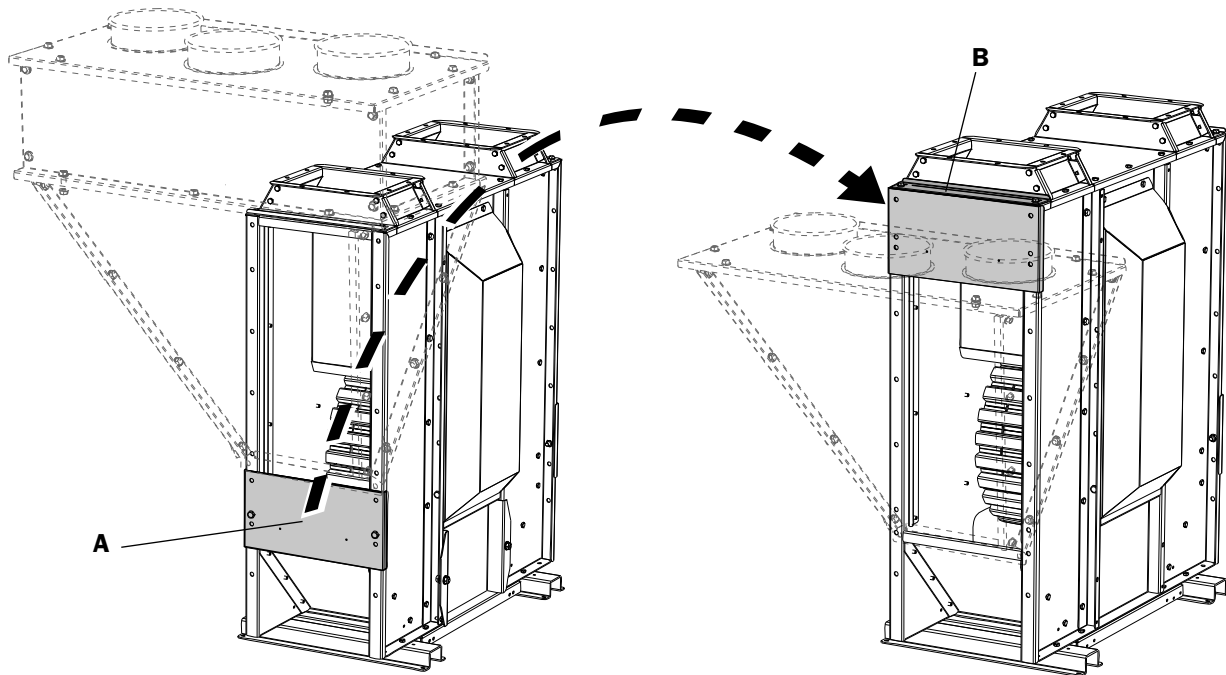

## Water seal

### **IMPORTANT!**

When assembling outdoors, seal all the bolts, flanges and folds with silicone.

## Inlet slide

### **IMPORTANT!**

- If feeding to the elevator is done from an intake pit or storage bin, the inlet must be regulated with a shutter.
- Ensure the elevator feed rate is not too high.

If the inlet slide is not being used, turn the bent edge of the rib plate (A) towards the leg.

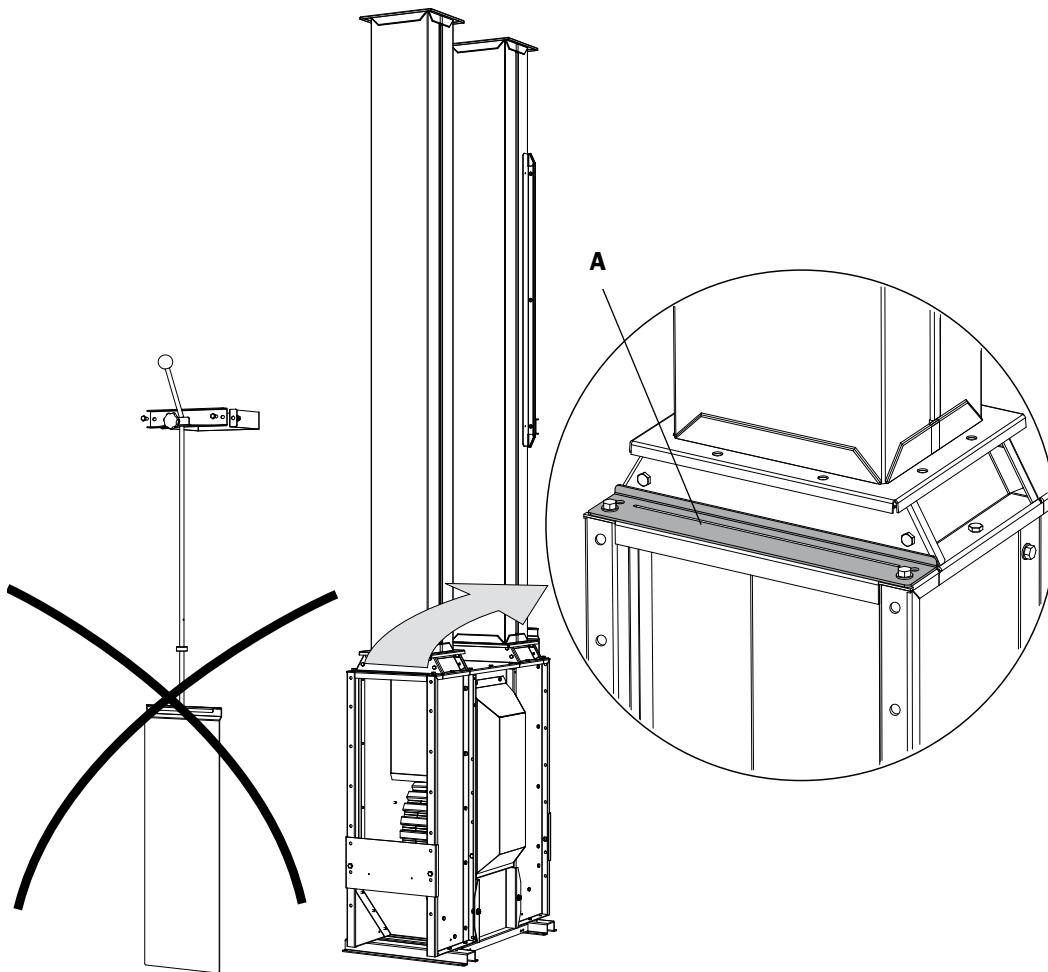

1.  
Fit the braces for the rod to the legs. The brace with the serrated knob (B) is to be placed at the top at a comfortable working height.
2.  
Position the rods through the braces and assemble them together with the stud to a suitable length.
3.  
Put the stop ring (C) on the rod under the brace with serrated knob.
4.  
Fit the control hatch on the rod and insert it through the rib plate (A).

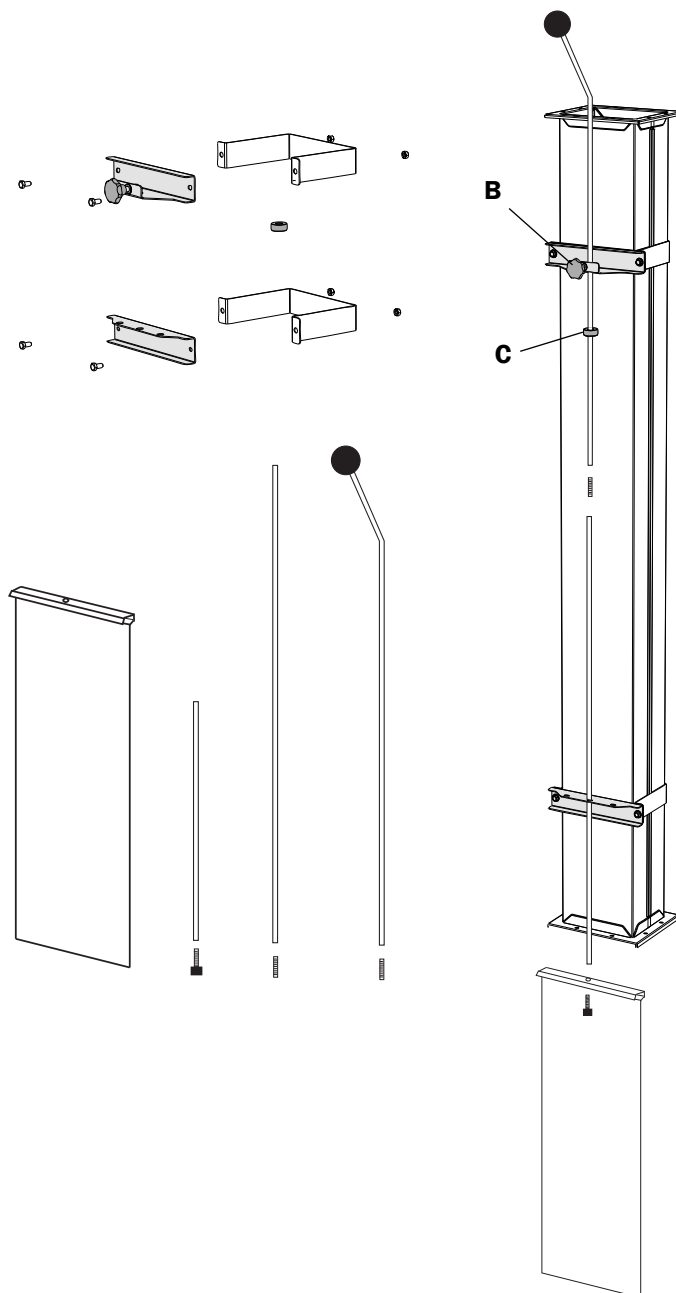

5.

**⚠ IMPORTANT!**

Position the stop ring (C) so that the control hatch can be opened fully without jumping out of the rib plate.

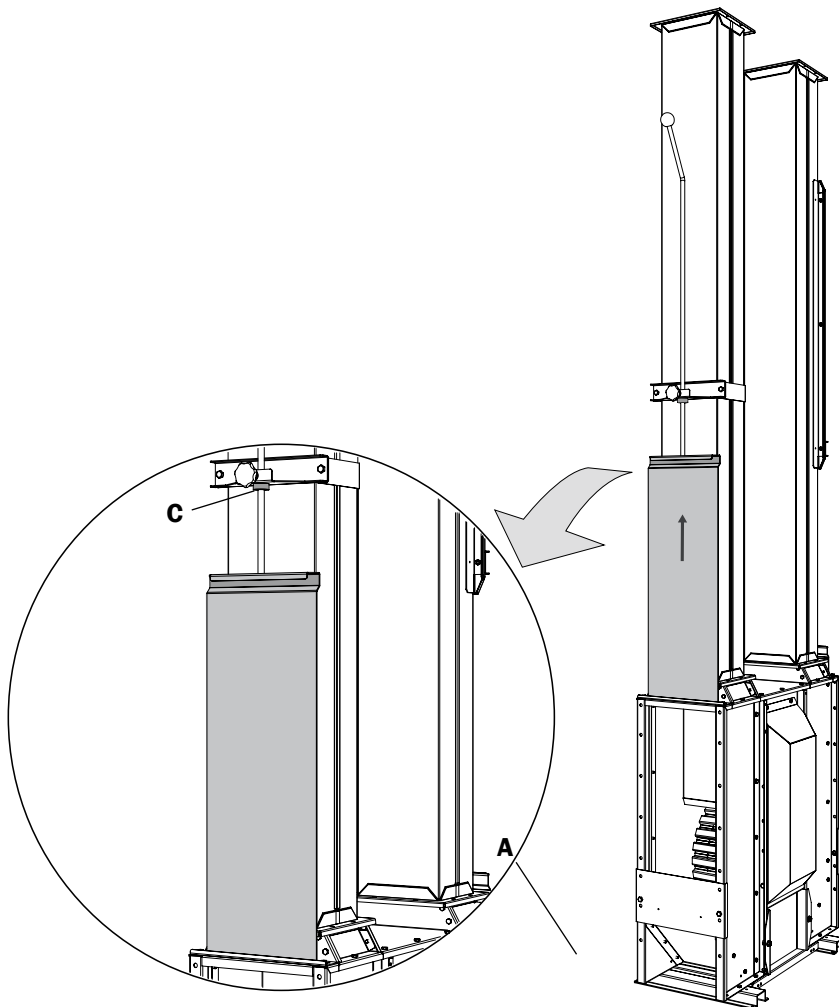







**SKANDIA**  
ELEVATOR

**SKANDIA ELEVATOR AB**

KEDUMSVÄGEN 14, ARENTORP  
S-534 94 VARA, SWEDEN

PHONE +46 (0)512 79 70 00  
FAX +46 (0)512 134 00

INFO@SKANDIA-ELEVATOR.SE  
WWW.SKANDIA-ELEVATOR.SE