



K-SERIES MOBILE DRYER



OPERATING MANUAL

M180k, M205k, M240k, M275k, M300k, M365k and M420k

ID: D00125-2018_EN Rev.A

MEPU Oy
Mynämäentie 59, 21900 Yläne, Finland
p. +358(2) 275 4444, mepu@mepu.com
www.mepu.com



TABLE OF CONTENTS

1	FOREWORD	3
1.1	WARRANTY AND WARRANTY TERMS	3
2	Important information for mobile dryer operators	4
3	Basics of grain drying	5
4	Technical specification of the mobile dryer.....	6
4.1	Hopper and feeding auger conveyor	7
4.2	Elevator	7
4.3	Pre-cleaner and spreader	7
4.4	Grain bin	7
4.5	Drying cells	8
4.6	Exhaust air cases and exhaust air aspirators	8
4.7	Feeding apparatus	8
4.8	Bottom trough, and bottom aspirator, sampling unit	10
4.9	Dryer furnace	10
4.10	Electrical equipment	10
4.11	Frame	10
5	Deploying and positioning of a mobile dryer.	11
5.1	Mobile dryer deployed indoors	11
5.2	Power supply.....	12
5.3	Electrical switchboard.....	13
5.4	Oil.....	16
5.5	Smokestack	16
5.6	Dryer furnace	17
6	Operating the dryer	19
6.1	Filling the dryer.....	19
6.2	Drying	20
6.3	Emptying the dryer.....	21
6.4	Dryer settings	23
6.4.1	Setting the filling delay	23
6.4.2	Cooling timer	24
6.4.3	Work/ pause time relay.....	25
6.4.4	Setting the burner thermostat.....	26
6.4.5	Setting of the drying thermostat	27
6.4.6	Setting of the feeding apparatus	28
6.4.7	Setting of the pre-cleaner aspirator.....	28
6.4.8	Setting the spreader disc.....	29
6.4.9	Setting the air flow rate	30
6.4.10	Drying of partial batches.....	31
6.4.11	Cleaning the central channel after drying a partial batch.....	33
6.5	Drying of different grain varieties	33
6.6	Aspects to be noted in respect of hot air dryers	33
7	Maintenance	34
8	Malfunctions	36



9	Concise operating instructions	38
9.1	In the beginning of the drying season make the following checks	38
9.2	Filling	38
9.3	Drying	38
9.4	Emptying	39
9.5	After the drying season	39
10	Technical data	40
11	User settings	43
12	Declaration of conformity	45

1 FOREWORD

This Manual contains instructions for operating a K-series mobile dryer.

Before starting to use the dryer please read the Manual carefully, and familiarise yourself with the operations and precautions, in order to ensure that you use the unit efficiently and safely.

Keep this Manual at hand, and review it always with any new employees. If you need additional information or help, please call your machine dealer or the Mepu Oy service number.

1.1 WARRANTY AND WARRANTY TERMS

This product is intended for professional use. Installation, operating and maintenance of the equipment presumes general skills and understanding of machinery and equipment, which a professional farmer is expected to have.

- The warranty period is one (1) year in agricultural use. The warranty period starts from the delivery of the product. The warranty period for the furnace and the heat exchanger is seven (7) years.
- The warranty does not cover any damages caused by misuse or any other damages resulting from the same.
- The warranty covers faults caused by poor workmanship and materials. Damaged parts are repaired or replaced with serviceable parts. If however it is established that the damage is not covered by the warranty, we shall charge for any expenses connected with the same.
- Warranty repairs do not extend the warranty period.
- The warranty does not cover consequential damages, resulting losses, lost profit, shipping costs, travel expenses, down time, modification of the original structure of the equipment or any other economic losses.
- The warranty shall apply in the event that the equipment has been installed, operated and maintained observing the instructions of the manufacturer and any effective regulations.
- The warranty does not cover premature wear or damage of parts resulting from negligent maintenance.

Any matters related to warranty and possible expenses have to be pre-agreed with Mepu Oy before performing any repairs.

2 Important information for mobile dryer operators



Avoid falling down

After having installed the grain silo fasten the ladder and back rails as well as the roof guardrails. Be particularly careful when working on the roof in rain, or if the roof is covered with ice.



Disconnect the dryer power cable from the network when you:

- Remove protective covers to carry out maintenance or adjustment work.
- Clean the bottom part of the elevator or the auger conveyor channel.
- Adjust the tension of the elevator chain or the conveyor V-belts.
- Go into the grain silo to adjust the spreader disc.
- Open the burner for maintenance.



Fire hazard; make sure that the dryer and its surroundings are clean

- The discharge pipes of the pre-cleaner and the bottom aspirator must be led sufficiently far from the dryer, and preferably take them via the cyclone to the debris bin. The air sucked into the furnace must be absolutely clean.
- Damp and partially dusty air from the side air channels must be led sufficiently far away from the dryer, so that it is not mixed into the furnace intake air.
- Mixing exhaust air with furnace intake air significantly reduces drying efficiency.
- It is advisable to check the cleanliness of the internal bottom of the furnace and the exhaust air channels every 100 hours. Moreover, at the end stage of every grain batch being dried, open the discharge lever, which is situated between the feeding apparatus and the elevator at the back of the dryer.



Avoid oil spills

Having adjusted the burner pressure make absolutely sure that you have closed the pressure gauge tap. If the tap is left open the pressure gauge can be damaged and fuel oil could spill into the environment. Protect the oil hoses between the oil tank and the burner such that they cannot be damaged by moving objects or people around the dryer.



Additional lighting

The drying season is at the end of summer, when evenings and nights are already dark. Therefore make sure that there is sufficient additional lighting around the dryer to ensure work safety.



Filling and emptying of the dryer

When you fill or empty the dryer make sure that no bystanders are threatened by the risk of being run over by the moving units or get crushed between the trainer and the hopper.



Extinguishing equipment

During the working season there must be a 12 kg ABE-3 type fire extinguisher on the dryer.



Operating instructions

Remember to read the operating instructions before installation of or operating the unit.

3 Basics of grain drying

The keeping quality of harvested grain depends on its moisture content and the grain temperature achieved by the method of storage. Under the conditions in Scandinavia and the northern hemisphere, the moisture content of grain after harvesting varies typically between 15–45%, which requires taking measures to improve the keeping quality of grain. The climatic conditions in the northern hemisphere prevent from achieving sufficiently low moisture content figures if just natural drying processes are used. During the harvesting season the relative air humidity can reach as high as 80–90%. Thus drying methods where no auxiliary equipment is used cannot produce low moisture contents. Therefore grain has to be handled applying various methods in order to improve its keeping quality. The established handling methods include various drying techniques and – in a smaller scale – freezing of grain.

The functioning of dryers is based on strong air flows circulating through the grain batch being dried, and subsequently discharging the air into the atmosphere. Dissipation of moisture can be facilitated by increasing the temperature of the grain being processed. The homogeneity of drying quality can be increased by circulating and cooling the grain during the drying process.

However, there are certain basic rules involved in the drying process, which should be observed to prevent drop of grain properties, such as germinative capacity or baking properties. The most important aspects that need to be monitored are grain temperature, circulation rate and air flow. These values vary by individual grain types and the case-by-case temperature settings must be determined through experience. The values are also affected by some dryer-specific aspects.

Approximate drying air temperatures:

Seed grain 50 ... 60° C

Bread grain 60 ... 70° C

Fodder grain ... 80° C

Recommended grain temperature:

Below 45° C ... germinative capacity drops

If drying is carried out in hot weather, make sure that the grain is circulated and dried properly in order to avoid overheating.

4 Technical specification of the mobile dryer

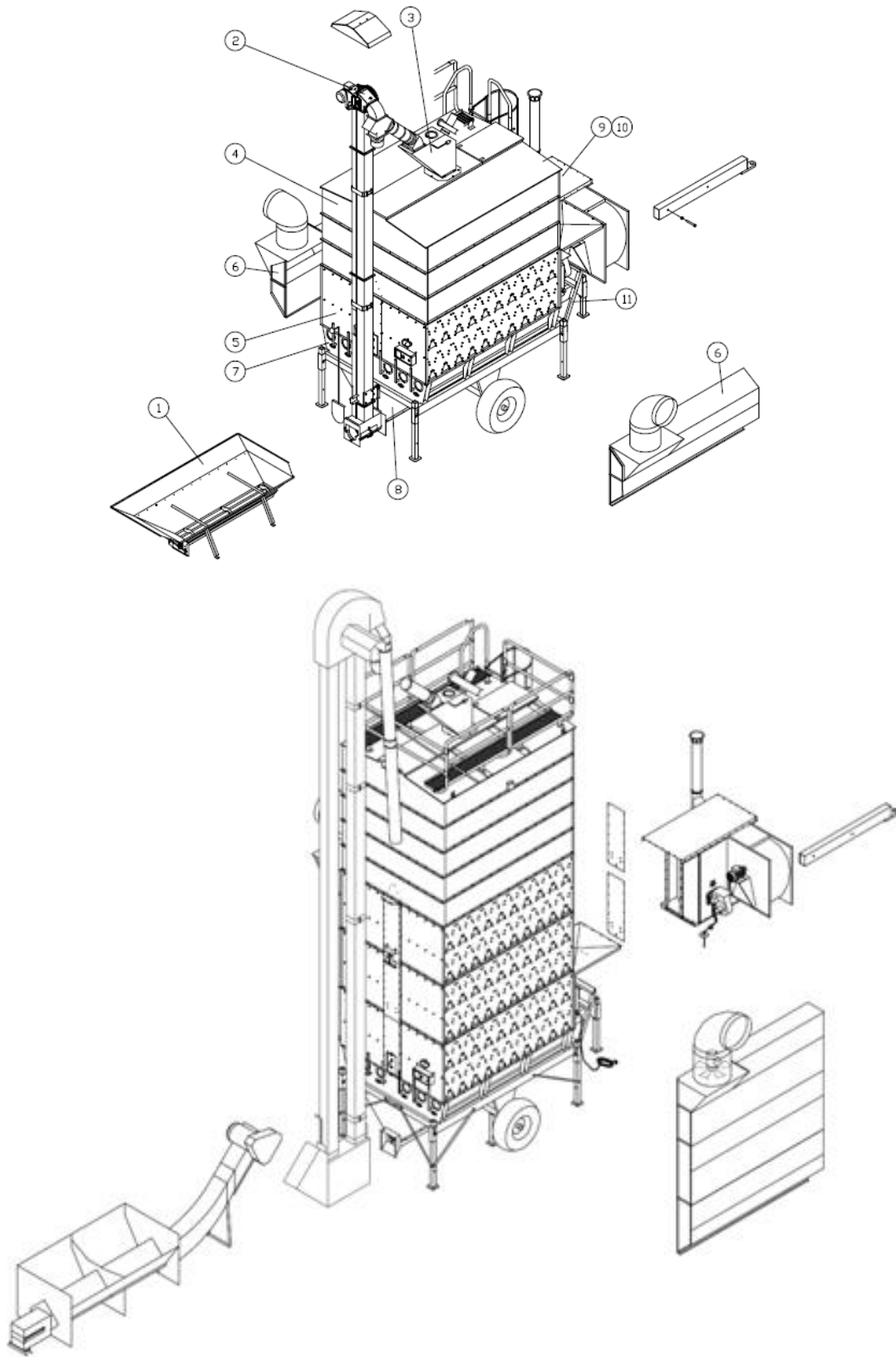

4.1 Hopper and feeding auger conveyor

Grain is loaded into the filling hopper equipped with a bottom conveyor, which feeds grain to the elevator. In rubber flap elevator models, the feeding auger conveyor features a manual disconnect switch, which allows disconnecting the auger conveyor from the rest of the removal equipment for the time of drying. The standard filling hopper is a 1.3m³ longitudinal hopper, which allows to dump the grain from the side, either from right or left. In bucket elevator models, the feeding auger operates with its own motor.

4.2 Elevator

Mobile dryers equipped with a rubber flap elevator:

Grain is lifted to the top of the dryer with a chain elevator. There is a 2-way divider at the top of the elevator, which allows feeding the grain either into the pre-cleaner and from there into the dryer, or into the discharge pipe. The bottom conveyor of the dryer is also powered by the elevator motor.

In a smaller model (180), the top of the elevator can be turned town to reduce the transport height.

Mobile dryers equipped with a bucket elevator:

The elevator is the Skandia bucket elevator featuring steel buckets. In this case the bottom conveyor is always equipped with its own motor.

The bottom trough under the bottom cone is equipped with a rotation sensor. The rotation sensor stops the unit when the dryer gets clogged.

4.3 Pre-cleaner and spreader

From the elevator, grain flows directly along the trough into the pre-cleaner, from where the grain will move directly to the spreader. The task of the motor-driven spreader disc is to spread the grain evenly throughout the grain bin. The vertically adjustable spreader disc is connected to the top conveyor via a bevel gear.

4.4 Grain bin

Moist grain swells when its temperature rises. When the drying process progresses the volume of grain is reduced significantly. The grain bin of the mobile dryer is optimised to function under any conditions. The purpose of a large grain bin is to act as a buffer when the grain level varies, which happens due to pre-cleaning and drying of the grain.

Guardrails and the access platform included in the standard delivery are attached to the top of the grain bin. There is an inspection hatch at the rear of the bin, which is used to monitor the dryer filling process. The standard delivery set also includes a rotating level guard, which stops the filling process when the dryer is full. The manhole on the roof gives access into the bin for adjusting the spreader disc or cleaning the insides of the grain bin.

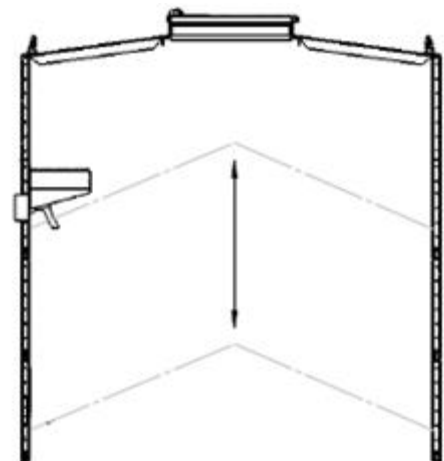

4.5 Drying cells

The drying cells have many air ducts. The drying process is uniform, because air is blown into the central channel between the drying cells, from where moist air is discharged through the drying cells towards the sides into the exhaust air cases. In the rear part of the central channel there is a cleaning/ inspection hatch. There are shutters preventing air flow installed between the cells for drying of partial batches.

4.6 Exhaust air cases and exhaust air aspirators

The task of the exhaust air cases is to collect the humid air from the drying cells, which is then lead through the exhaust channels towards the sides of the dryer. One of the exhaust channels features a thermostat that measures the exhaust air temperature. The digital display of the thermostat is located in the electrical switchboard.

The exhaust air aspirators for the exhaust air cases are available as optional equipment. The aspirators serve to reduce condensation of moisture in the exhaust air cases. The aspirators also improve ventilation inside the dryer.

4.7 Feeding apparatus

During the drying process grain flows from the rotating feed rollers evenly down into the conical base. There are six speed rollers in the dryer. At both ends of the feeding apparatus there are movable hatches for cleaning the feed rollers.

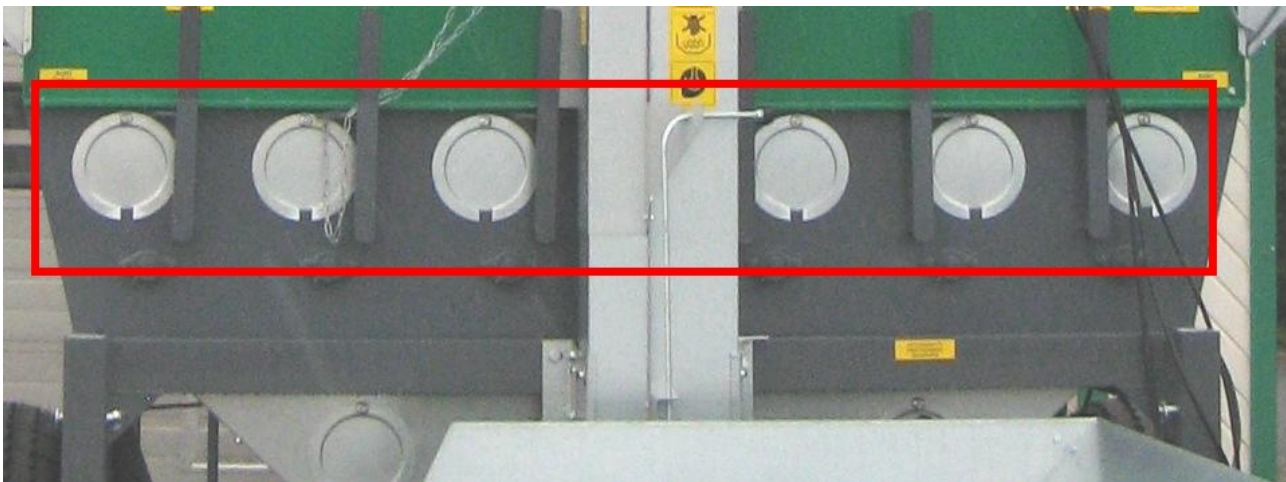

The volume of the feeding apparatus is 0.81 cubic metres. The shafts feature with ball bearings at each ends, and a nylon sliding contact bearing at the centre. There is a hatch underneath each feed roller, which is opened when the dryer is unloaded.

The five blade feed roller functions smoothly, even when the grain humidity is high, and the feed rate stays uniform in terms of volume throughout the entire drying process, regardless of the moisture content of grain. However, it is important to note that the flow increases in terms of weight towards the end of the drying process as the grain size is reduced.

The steep-angled feed troughs ensure even drying process and reliable circulation under any circumstances. The structure of the feeding apparatus is very tight, allowing to dry even small seeds (such as turnip rape).

The feeding apparatus features a bottom hatch shut-off mechanism to open and close the bottom hatches. The opening mechanism is operated either with a cam.

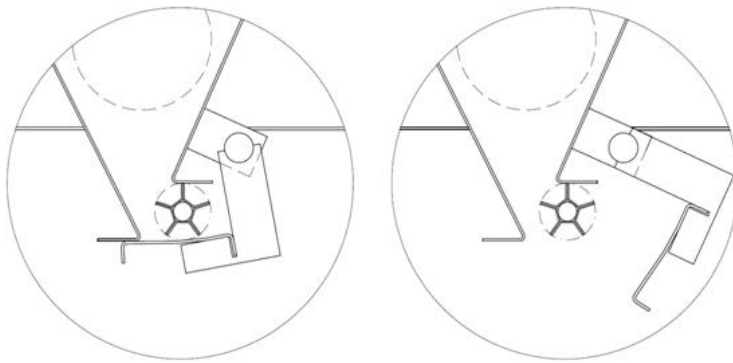

The feeding apparatus with a cam operated bottom hatch opening mechanism features a separate cam for opening and closing every bottom hatch. In such a feeding apparatus the second and the fifth cam (see Figure) has an intermediate position, which can be used to control the flow of grain into the bottom trough when the hatches are opened with the cam.



CLOSED



INTERMEDIATE POSITION

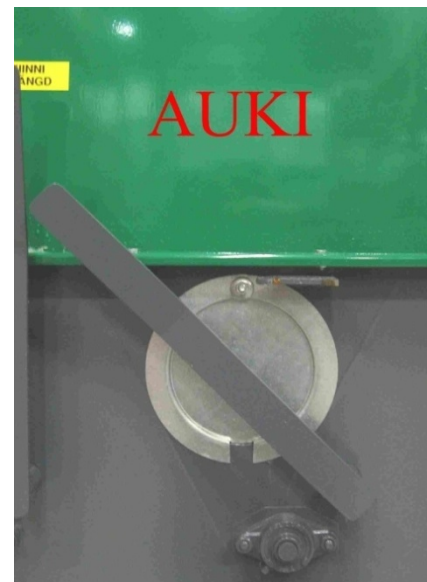

OPEN



All bottom hatches must be closed during the drying process or filling the dryer!

The bottom hatches must not be closed, if there is grain in the bottom trough (risk of damage).

The driving engine of the feeding apparatus is an inverter-controlled gear motor, from which the rotating movement is transmitted through the chain drive to the feeding shafts. At the production facility the grain circulation rate is adjusted to approximately 182 hl/ hour. The feeding amount can be freely adjusted by rotating the control knob on the electrical switchboard.



4.8 Bottom trough, and bottom aspirator, sampling unit

The steep-sided bottom trough is made of durable hot galvanized steel plates. The bottom aspirator removes dust and steam from the bottom trough, keeping the elevator clean throughout the entire drying process. From feed rollers the slanting sides of the trough direct grain to the bottom conveyor on the bottom of the trough, which removes the grain to the elevator. The sampling unit is located in the rear of the bottom trough.



The sampling unit facilitates monitoring of the drying process. Remove the cover and tilt the sampling tube downward and let grain fall into the sampling bin.

4.9 Dryer furnace

All dryer models feature an efficient and durable furnace. Power range of the furnaces: 250–500 kW. The blower capacities /air rates are: 4.0–11 kW / 14000–24500 m³/h.

The burner flame burns in the middle of the cylindrical firebox, and heat is transmitted into the vertical plate heat exchangers. The combustion chamber is made of fire-resistant steel. The vertical heat exchangers release heat evenly and efficiently. This ensures excellent efficiency and durability of the furnace.

4.10 Electrical equipment

The electrical equipment and automatic systems of the dryer are installed at the factory. The dryer is ready for use as soon as the dryer's equipment is connected to the respective outlets, the unit is connected to the power network, and the oil burner hoses are placed into the oil tank.



Before starting any maintenance work remember to always turn the main switch into the OFF position, or disconnect the power cables from the network.



4.11 Frame

The sturdy steel beam frame and large air filled rubber tyres make it possible to transport the dryer at the maximum speed of 50 km/h. During the drying process, the frame must be supported at five support points. On M240k and larger dryers the wheel shaft is supported with shaft supports. The drawbar can be detached to save space.



Towing of a mobile dryer filled with grain is categorically prohibited.

5 Deploying and positioning of a mobile dryer.

Mobile dryers need not be placed in a building. The design of a mobile dryer permits using it outdoors without any special protective structures. Nevertheless, it is advisable to build a light unheated shelter around the dryer, or an element silo to be used as grain storage, which also gives the structure its walls. If a more permanent building is constructed, note the aspects related to building permits.



Always contact the local construction and fire rescue authorities before you start the installation.

5.1 Mobile dryer deployed indoors

Air flows of a dryer positioned indoors shall be arranged such that dust from the cleaners and outlet ducts does not get mixed into the dryer intake air.

When selecting the deployment site make sure that the required electrical and oil connections are available. Select such location for the oil tank or oil barrels that the oil lines do not cross any passageways, in order to prevent them from getting damaged. The oil tank must be placed at least 3 m away from the dryer.

In other respects the dryer shall be located in the optimal place and such that there is enough space for the trailer-tractor combination for driving and turning around. The place where the dryer is installed has to be as level as possible in relation to the frame of the dryer, and have sufficient load-bearing properties, e.g. a concrete slab. Moreover, it is necessary to consider any dust and noise hazards.

Before commissioning the dryer it is advisable to set up a block for the trailer, in order to avoid damaging the hopper. If the dumping height of the trailer is low, it is advisable to build a ramp for the hopper.

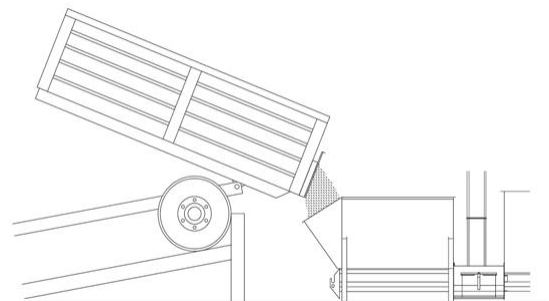

Air flows in an enclosed space

The intake air has to be taken from outside the building using an extension pipe (A). The debris/ dust pile (B) of the pre-cleaner and the bottom aspirator have to be led through the cyclone out from the building into a separate dust collection bin. Exhaust air pipes (2 pcs) are taken outside the building (C). The smokestack is led outside the building (D). The grain line is installed such that the loading is flexible (E). Make sure that the furnace gets dust-free air in any conditions.

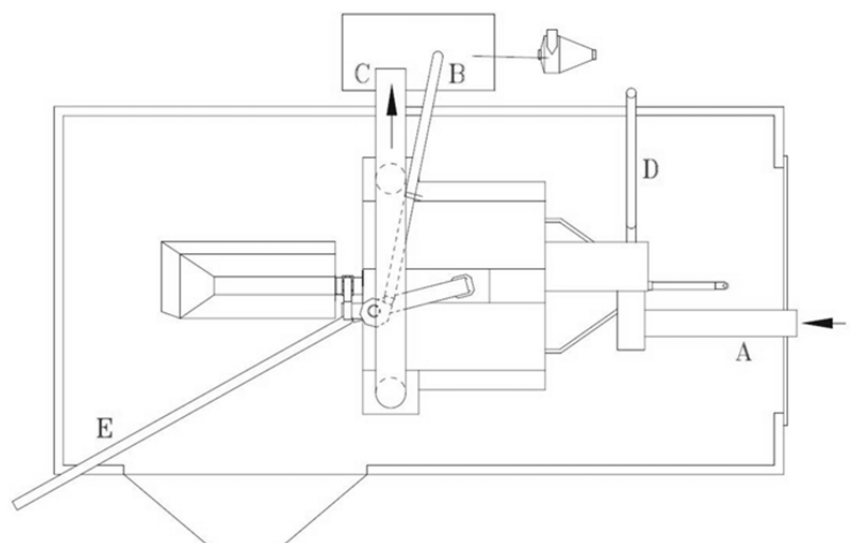

5.2 Power supply

The electrical equipment is installed and tested at the factory. The unit is equipped with a 10 m electrical cable with either 32 A or 63 A plugs. If you need more cable, it has to be of the VSEN 5x6 mm² type. Any dryers sized 240K and larger: use cable 5 x 16 mm². An undersized cable can overheat, causing hazards and other malfunctions. If more than 50 m of cable is needed, check with the local electrician to establish the proper cable size.

The elevator, pre-cleaner, the spreader and the feeding auger conveyor with its own motor, are connected to the power circuit of the dryer via the sockets located on the electrical panel on the rear wall of the dryer. The panel also features the I/O switch operating the conveyor equipment.

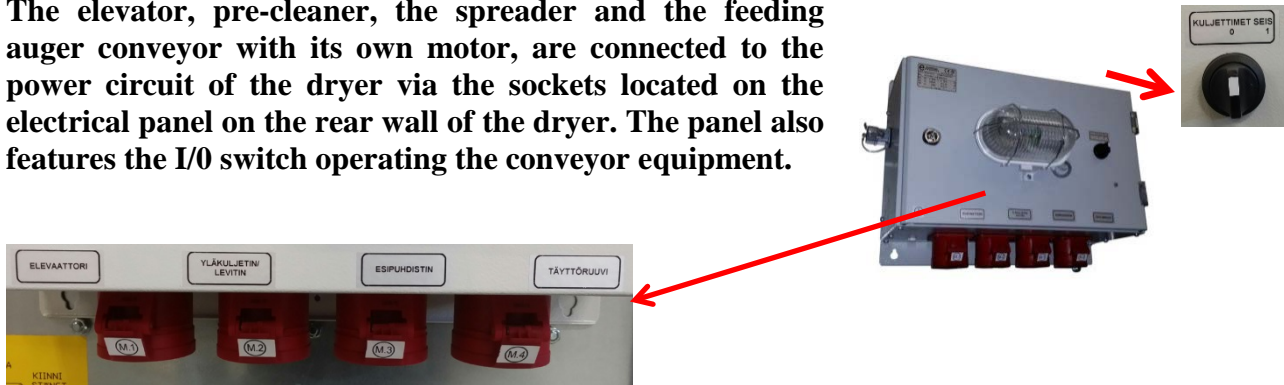

The bottom aspirator is connected to the socket (2) at the front of the bottom trough.

The **speed sensor of the bottom conveyor** is connected to the rectangular socket (3) located on the front side of the bottom conveyor and the bottom trough.

The **bottom conveyor featuring its own motor** is connected to the power socket (1) on the front wall of the bottom trough. OPTION



Dryer power supply

The feeder cable is connected to the connector on the side of the electrical switchboard. If the cable is connected to the power network, the main fuse capacity has to be at least 25A–63A, depending on the equipment installed on the unit. If the unit is connected to the power network and the main switch is turned to position I, the work lights of the unit (1 next to the electrical switchboard, 1 at the rear of the unit) are turned on.



The cable and the fuse size of the unit vary depending on the equipment installed on the unit.

When connecting the unit to the power network, make sure that the main switch is in the OFF position.

Checking the rotation directions

The rotation directions of all motors are checked at the factory during the test run. However, when you connect the dryer at the deployment site it is advisable to recheck the directions of rotation. The best way to do it is to check the direction of rotation of the furnace fan. Keep the dryer mode switch in the position 3 (drying) for about 3 seconds, and after that it is possible to check the rotation direction of the furnace fan. The correct direction is indicated on the sticker located under the fan's intake.



If the dryer's power supply is moved to another socket, or if the dryer's extension cord has been replaced, check the rotation direction again.

Also note that the power supply has to be a five-wire system, i.e. L1, L2, L3, N and PE.

5.3 Electrical switchboard



A. Group fuses and earth leakage circuit breaker. The actuators are protected by fuses and an earth leakage circuit breaker.

B. Main switch. Under the protective cover. The electrical equipment of the dryer can be disconnected from the power network. The switch must always be turned to OFF position, when any maintenance work is carried out.

C. Drying process selector switch, see section: 6. Operating the dryer, on page 20

D. Emergency stop button. The emergency stop button is used to stop the dryer in case of an accident or emergency (may be used only in case of an emergency).

The electrical switchboard has been pre-installed, adjusted and tested at the factory.

Data label of the switchboard.

Using the number and the year of the label you can order new electrical switchboard labels, if necessary.



Electrical switchboard cabinet, Signal lights and control buttons

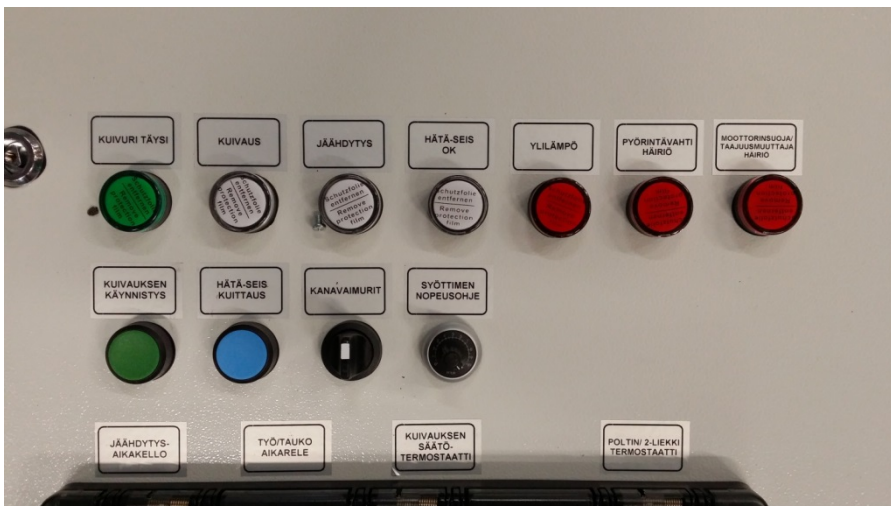

Actuator	Actuator use
Dryer full	Lights up when the dryer is full.
Drying	Lights up when the drying is switched on.
Cooling	Lights up when the cooling is switched on.
Emergency stop OK	Light normally on. Turns off if an emergency stop button has been pressed.
Overheating	Lights up if the machine has overheated.
Rotation detector malfunction	Lights up if the rotation detector has malfunctioned, stops the bottom auger and the elevator.
Engine protection Frequency converter malfunction	
Drying start	When all drying settings have been selected, the drying start

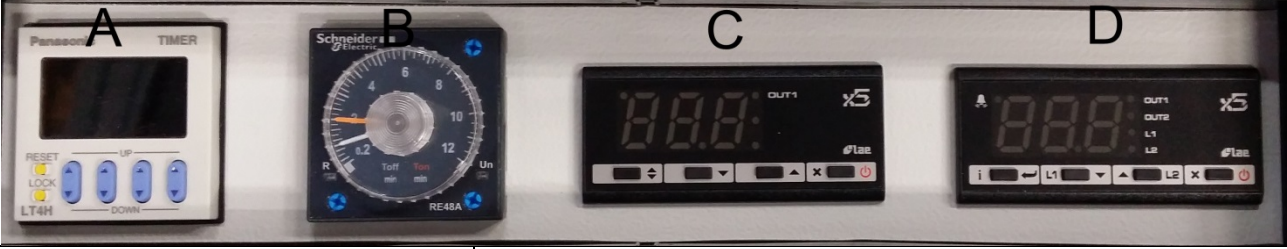
	switch is turned to position 3 “Drying”, and the start button is pressed, and the drying process will begin.
Emergency stop reset	Resetting the emergency stop button. Before resetting, all emergency stop buttons must be released. Emergency stop buttons can be released by rotating or pulling them upwards. After this, press the emergency reset button.
Channel aspirators	Channel aspirators can be removed from use or put to use during the drying process.
Feeder speed control	Adjusts how quickly the grain rotates inside the dryer
Under the protective cover	
	
Cooling timer	Adjusting the length of the cooling time. Cf section: Cooling timer Cooling timer, page 22
Work/pause time relay	Cf. section: Work/ pause time relay Work/ pause time relay, page 25
Drying adjustment thermostat	Adjusting the temperature range of the drying; i.e. at what temperature the drying will move on to cooling.
Burner 2-flame thermostat	Adjusts the blasting temperature from the furnace to the dryer.



The blower and the overheating thermostats are read from the position of 9 o'clock. Both thermostats are pre-set at the factory. See section: Factory settings, on page 18

Electrical switchboard upper cabinet

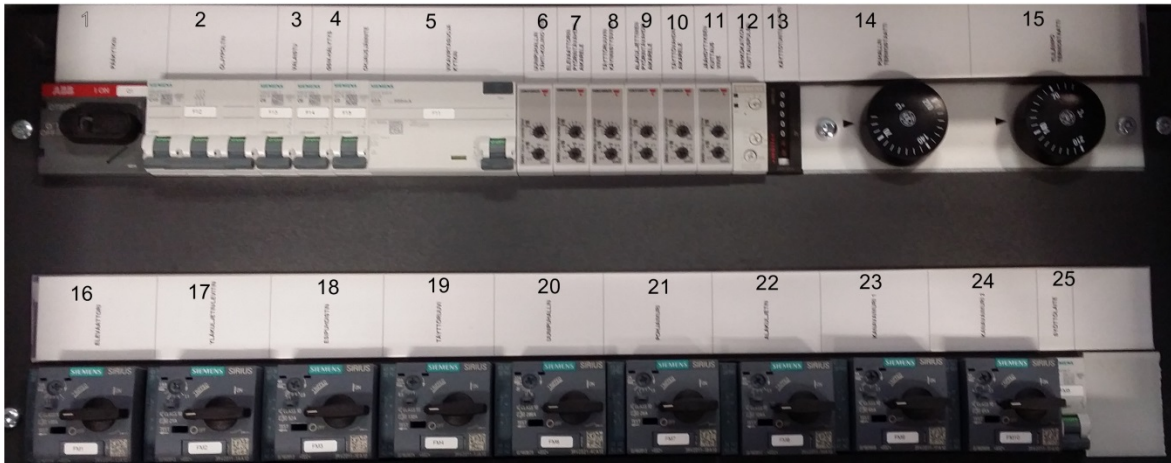

1	Main switch	9	Bottom conveyor. Rotation detector	17	Spreader disc
2	Oil burner	10	Feeding delay adjustment	18	Pre-cleaner
3	Lighting	11	Cooling	19	Feeding screw
4	GSM alarm	12	Power off	20	Main blower
5	Fault current protection	13	Operating hour counter	21	Bottom aspirator
6	Furnace blower, delay	14	Blower thermostat	22	Bottom conveyor
7	Elevator rotation detector	15	Overheating thermostat	23	Channel aspirator 1
8	Feeding screw	16	Elevator	24	Channel aspirator 2
25	Feeding apparatus				

If the group fuses tend to trip often, contact an electrician to have the unit fixed so that it is safe to use.

5.4 Oil



So that the warranty would remain valid for the Oilon oil burner, fixed pipes must be installed to the burner, and the installation work may be carried out only by a company specialised in oil burner installations and approved by Tukes (The Finnish Safety and Chemical Agency).

Check with the authorities in your country to find such approved specialised workshop. Information about the burner and its installation can be found in the burner manual, which is included in the set of dryer documents. Register your burner online through the Olion Care service to ensure the validity of your warranty.

5.5 Smokestack

The dryer delivery set includes smokestack sections, connecting collars, the ash / soot removal elbow, as well as a rain cap. The outlet pipe starting at the side of the furnace is connected to the ash/ soot removal elbow and 2 or 4 m (depending on the size of the unit) smokestack sections along with the rain cap. The smokestack sections are intended for outdoor use. When installing these indoors, additional insulation is required; it is recommended to consult with the local fire safety authority before the installation.



Contact the local fire rescue or construction authorities to establish the appropriate location and height of the smokestack.

5.6 Dryer furnace

Deployment

The furnace installed on the mobile dryer is ready for use, after the on-site electrical and oil circuit connections have been made. Before starting the drying mode, check the following furnace parts:

- Check that the oil hoses are connected correctly (the arrow on the filter and the pump indicate the suction and return sides).
- Check that the oil filter is upright.
- Check that the explosion hatch and the soot hatch are closed.
- Check that the smokestack is compliant with the requirements and is tightly fastened to the dryer.

The economy of the drying process can be significantly affected by two furnace related aspects: Therefore, before commissioning the dryer, read the furnace operating and maintenance manual carefully. The furnace settings must always be checked with the furnace installer in order to ensure clean burning and low oil consumption. The warranty is valid, provided that the burner is serviced annually by a professional.

Burners and nozzles

The nozzle capacities shown in the table are intended for 10 bar oil pressure. The nozzle capacities can be reduced below the values shown in the table, if necessary. The 1 and 2 stage ratios can also be modified, but the total capacity of the nozzles must not be exceeded.

Furnace type	Burner	Max power [kg/h]	Nozzle size I stage	Nozzle size II stage	Nozzle kg/h	power	Flame plate setting [mm]
210	Oilon KP 26	19	4 gal 80°		14.2		46
210	Oilon KP 26 H	19	3.5 gal 80°	1.5 gal 80°	12.9 + 5.84=18.8		42
250	Oilon KP 26 H	23	4 gal 80°	2 gal 80°	14.2 + 7.4=21.6		43
300	Oilon KP 26 H	29	5 gal 80°	2 gal 80°	18.5 + 7.4=25.9		50
400	Oilon KP 50 H	38	6 gal 80°	3 gal 80°	23.4 + 11.6=35		2.7
500	Oilon KP 50 H	48	8.5 gal 80°	4 gal 80°	33.1 + 14.2=47.3		4.6



The nozzle spray angle must be 80 degrees. Exceeding these nozzle capacities cause the warranty to become void.

Furnace temperature settings

If the drying air temperature rises above the set value of the burner thermostat, the burner shall stop and will restart when the temperature has dropped by 2–4° C.

If the furnace is equipped with a 2 stage burner (KP 26 H or KP 50 H), the thermostat has two settings, one for 1 stage and the other – for 2 stage. In this case note that the setting for the 1 stage has to be higher than the setting for the 2 stage. The idea is that the burner should never switch off during the drying process; instead the 2 stage should compensate the variations of the outdoor temperature. If the outdoor temperature drops, the 2 flame shall burn for longer intervals, while rise of the outdoor temperature reduces the need for the 2 flame.

The setting value of the overheat thermostat is a bit higher than that of the burner thermostat, and it makes sure that the temperature of the furnace does not rise too high. If the dryer is stopped in the middle of the drying process, the fan thermostat stops the furnace fan only after the furnace temperature has dropped below the temperature value set for the fan thermostat.

Factory settings

Unit	Type	Factory setting	Action
Fan thermostat	Capillary	50 °C	The fan starts when the temperature is exceeded. Always make sure that the dryer power is switched on.
Burner thermostat 1 stage	Digital	90 °C	Puts the 1 stage flame off at this temperature. The nozzle has to be dimensioned such that it does not put the 1 stage flame off.
Burner thermostat 2 stage	Digital	80 °C	Puts the 2 stage flame off at this temperature.
Overheat thermostat	Capillary	120 °C	If the temperature is exceeded, switches to overheat -> alarm.
Drying process setting thermostat	Digital	50 °C (30-50) °C	Factory setting 50°C, normal operating setting 30 - 50. If the set value is exceeded, switches over to cooling.
Cooling timer	Digital	1h:30min	When the cooling is activated, the clocks starts counting down the cooling time. After the time has lapsed, the unit is switched off. Minimum value 1 min.
Level guard delay	Digital	5s	The period during which the dryer is being filled after the sensor has given the signal.
Pre-cleaner setting	Manual	1/2	At the mid-point. If it is open too much, grain can get mixed into the debris.
Pre-cleaner weight	Manual	Right at the bottom	Evens up the flow of grain into the dryer.
Spreader disc	Manual	Holes 3 cm open	Down, and the bottom holes open by ca 3 cm.
Main fan setting	Manual	Fully open	Limits the air flow if necessary.
Partial batch shutters or central channel hatches	Manual	Open	Normally open. For partial batches – closed. Opens or shuts off the air flow to the top drying cells.
Feeding apparatus hatches	Manual	Closed	To be kept closed Opened, if required, for emptying.
Feeding speed	Electrical	5	At the mid-point. Measure the time when emptying with the feeding apparatus, and adjust the feeding apparatus speed, if necessary.

6 Operating the dryer

The drying process consists of four different stages. Filling, drying, cooling and emptying.

6.1 Filling the dryer

Preparations

Before starting the operations determine the suitable trailer dumping height, and remember to set up a block for the trailer, to avoid damaging the hopper.

Check the following before dumping:

1. That the shutters of the feeding apparatus are closed. Make sure that all the shutters are tightly closed.
2. That the divider at the top end of the elevator is in position 3 “drying”, i.e. the grain is flowing into the dryer unit.
3. That the switching cam of the feeding auger is in the “closed” position.
4. That the air intake shutter is adjusted correctly, so that kernels do not fly into the debris pipe.
5. That all the inspection doors are closed.

Filling

After preparation you can start filling the dryer by turning the selector switch on the electrical switchboard to position 2 “filling”. This activates the elevator system and the pre-cleaner motor. After that you can start pouring the grain into the hopper.

If necessary, e.g. when the empty trailer is changed for a full one, the filling can be stopped either with the 1/0 switch at the rear of the dryer, or with the selector switch. If the time for changing the trailers is short (less than 15 minutes), there is no need to stop the filling process. If no new grain is delivered, the conveyors should be emptied of the grain, in order to minimise the clogging risk when the next filling process starts.

The level guard stops the filling process with a short delay, after the grain level has reached the level guard sensor and blocked its rotating action. The level guard delay time is set at the factory. When the dryer is full, there should be about 30 cm of free space below the lower edge of the spreader disk.

If the dryer is too full the grain blocks the functioning of the spreader disk. If the spreader disc cannot rotate, the thermal relay of spreader disk will trip. Reset the thermal relay after about 15 minutes, and remove excess grain from the dryer.

To empty the dryer turn the divider away from the dryer, move the trailer under the pipe, and move the selector switch to position 1 (emptying). Check the grain level from the manhole. After discharging a sufficient volume of grain stop the emptying process by turning the selector switch to position 0.

Before starting the drying process disconnect the hopper bottom auger from the elevator, by pulling the switch cam backward. After that, close the shutter between the bottom end of the elevator and the hopper. If necessary, you may leave some grain in the hopper.



In hoppers equipped with their own engine the auger is automatically controlled. When the filling process is activated, the hopper auger starts automatically, and stops respectively, when the unit is full.

6.2 Drying

Preparations

Check the following before starting the drying process:

1. That the divider is in the drying position.
2. That the conveyor switch on the rear box is in the position 1.
See.
3. That the switch cam of the feeding auger is pulled out.
4. That the furnace connections and settings have been checked.
5. Check the burner to verify that the burner switch is in position 2 (KP 26 1 stage burner in position 1).
6. CONSIDERATIONS WHEN DRYING PARTICULARLY WET GRAIN

If the humidity of the grain exceeds 25%, this equipment will function differently than during normal years. When drying particularly wet grain, it is recommended to increase the temperature gradually, so that the grain would not become clumped and the grain could move smoothly through every part of the equipment.

Between drying batches, we recommend checking that there are no grain clumps in the corners of the dryer; remove clumps when necessary.

Drying

Having checked all of the above, start the drying process. First use the cooling timer to set the appropriate cooling time, which depends on the size of the unit or the outdoor temperature. The cooling time of a smaller unit is ca 1 hour, and that of a larger one – 1.5 hours. However, the cooling time is set such that the batch being dried makes at least one full circle. When the weather is hot, the cooling time should be longer.



After that turn the selector switch to position 3 “drying”, and press the **Drying Start** button.

The drying stage starts with the activation of the main fan. The burner ignites after a short time delay. The dryer features a staggering device, which controls the conveyor system during the drying stage. The drying starts always at the pause time set by the work/ pause timer, which means that its duration (adjustable) determines the moment when the burner activates. After the burner has ignited, check the functioning of the dryer.

When the drying process starts the grain feeding equipment is activated as well. The feeder installed at the bottom of the silo feeds the drying grain evenly to the bottom trough, from where it moves to

the bottom conveyor located horizontally in the bottom part of the dryer. The bottom conveyor moves the grain to the elevator, from where it is delivered through the pre-cleaner and the spreader disc back to the grain bin. The temperature of exhaust air is monitored with the sensor installed in the exhaust air duct. When the set value has been achieved, the automatic system stops the drying operations and activates the cooling process.

The feeding apparatus is adjusted to factory settings. This setting should be checked with your own type of grain. If the dryer is used to dry e.g. turnip rape or grain with a higher than normal moisture content, the settings of the feeding apparatus should be modified. Also check the functioning of the pre-cleaner, and change its settings, if appropriate.

 **Before emptying the dryer check the moisture content of each batch using a moisture meter.**

Now the drying phase continues until the drying thermostat measuring the exhaust air temperature stops the burner. This automatically activates the cooling phase, which lasts for the time set by the cooling timer (1–1.5 h). When the main fan stops the drying phase (cooling) has been completed. If there is a power outage during the drying phase, the drying phase restarts automatically when the power supply is restored. Always check the drying result before emptying the dryer. Take a sample from the sampling unit and check the humidity of the grain with the moisture meter.

6.3 Emptying the dryer

Preparations

1. Move the divider into the position of emptying the dryer into a silo or a trailer.
2. Check the fastening of the grain pipes.

Emptying

Start the emptying process by turning the selector switch to position 1 “emptying”. After that open the middle bottom hatches halfway. Then steadily open the bottom hatches one by one. Always pause between opening each hatch, this prevents grain from rushing onto the elevator.

The grain is moved with the bottom conveyor to the elevator, which lifts it up. From the elevator grain drops to the divider, which directs the grain via the pipe to the storage silo or onto the trailer.



After no more grain comes out from the discharge pipe, check from the inspection door of the feeding apparatus whether the dryer has been emptied. Close the bottom hatches and open them once again to ensure that the dryer is empty. Do not forget to always close the bottom hatches after checking. Switch the dryer off by turning the selector switch to position (0).

The bottom part of the elevator can be emptied by opening the bottom cover equipped with a quick-release latch. Open the cover only after the dryer main switch has been turned off.

The trough on the bottom conveyor can be emptied by unscrewing the screws (2 pcs) on the hatches.



Close the bottom hatches immediately after emptying in order to ensure that they are not open before the dryer is filled next time.



The bottom hatches must not be closed, if there is grain in the bottom trough (risk of damage).

Before any maintenance covers of the elevator or the auger conveyors are opened, make sure that the main switch is turned off. Always make sure that the controls of the dryer are not energized before starting any maintenance on the dryer.

6.4 Dryer settings

6.4.1 Setting the filling delay

The delay time of the level guard can be adjusted on the electrical switchboard. The timer of the level guard is situated in the upper cabinet of the electrical switchboard (10). The filling of the grain bin can be adjusted with the delay of the level guard. The delay causes grain to reach above the level guard during a set period of time. This allows to ensure that the grain bin is filled appropriately. The level guard delay time is set at the factory to 5 seconds. The delay time can be changed as required.

The timer has two settings. The timer delay adjustment is above, (A) Time; and the time range selection Range (B) is below.

Using the adjusting wheel (A) set the time within the time range. If the time range set by (B) is 1s, it means that on the adjusting wheel (A) 1 equals 1 second and 10 equals 10 seconds. Change the time range (B), if the time (A) is not enough to sufficiently fill the dryer < (10s).

Check the fill level after every adjustment. Adjust the time by small increments to prevent the machine from getting clogged. Note that with different grain types or humidity levels the filling time can vary.

A. **Time** = 5 (factory setting)

Defines the level guard delay

If Range is 1s, then 5 = 5s

If Range is 6s, then 5 = (6 x 5) = 30s

If Range is 60s, then 5 = (60 x 5) = 300 s = 5 min.

B. **Range** = 1s, The delay is adjusted by increments of 1 second (factory setting).

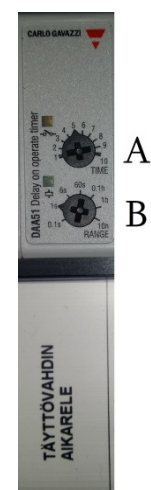

6.4.2 Cooling timer

The start display of the cooling timer is shown at pos. (A). After the set time has lapsed and the timer has stopped the equipment, the drying process has ended, pos (B).

Pos. (C) shows a situation when the Lock (2) key has been pressed, the keys are locked and are released only after the Lock (1) is pressed again.

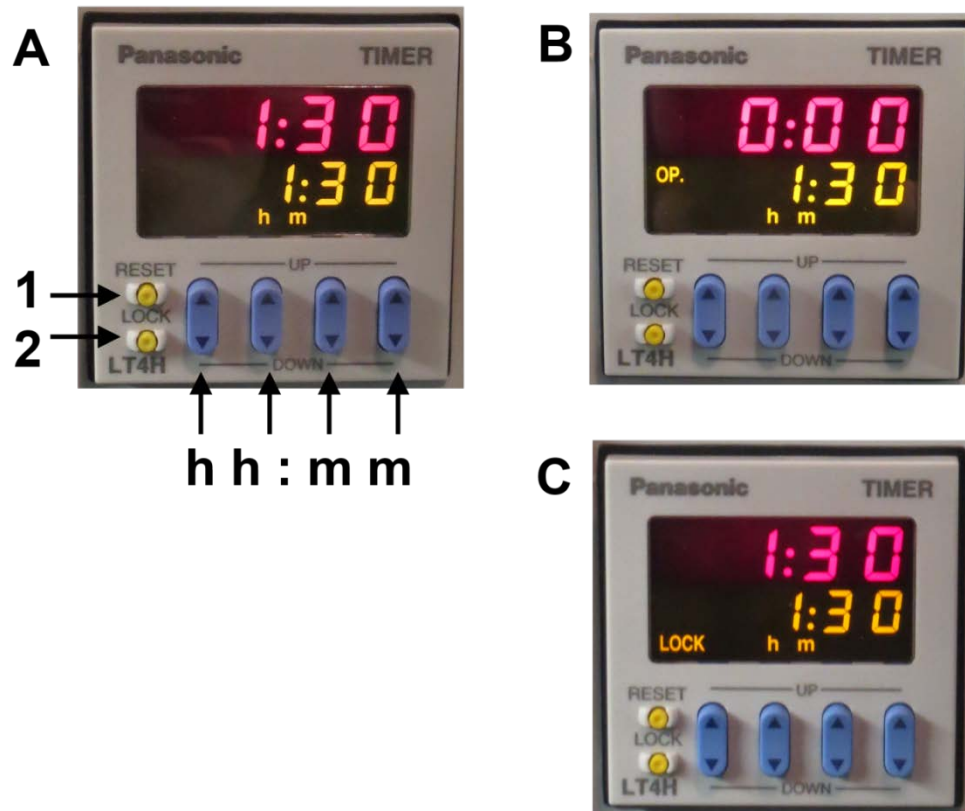

Setting the cooling time before drying

The cooling time is set by pressing the hh:mm keys. After the desired time has been set, press the Start button. This confirms the set time, and the set time is displayed on the top row (red numbers). When the dryer switches over into the cooling mode, the timer starts the count-down, and the remaining cooling time is displayed on the timer (red numbers).

Modifying the time when the dryer is running.

The time can be modified either in the drying mode or in the cooling mode. Using the hh:mm keys, select the new time setting, and press the Reset (1) button. The set time is displayed in red, which means that it has been accepted. In the cooling mode, the new setting is the new cooling time. This makes it possible to stop the cooling process, e.g. set the time as 1 min., and press Reset (1). After one minute the cooling process ends and the dryer stops.

6.4.3 Work/ pause time relay

The timer is situated on the cover of the electrical switchboard. When starting the drying process note that the burner will ignite after the set pause time. This means that the drying process starts with a pause. In chain elevator machines, factory settings have been set as 60 seconds of operation time for the conveyors, then stopping for 120 seconds to wait for the accumulation of grain on the bottom conveyor. In bucket elevator machines, conveyors will operate for 80 hours and stop for 1 s; in practice, a bucket elevator machine will not stop during the drying process.

The running and pause times can be adjusted as appropriate. The red hand is the running time, which is adjusted with the smaller wheel (5), and the white hand is the pause time, which is adjusted with the larger wheel (6). The functioning of the timer can be checked with the signal lights, where light R (7) represents the running phase, and the flashing Un light means that the system is on pause.

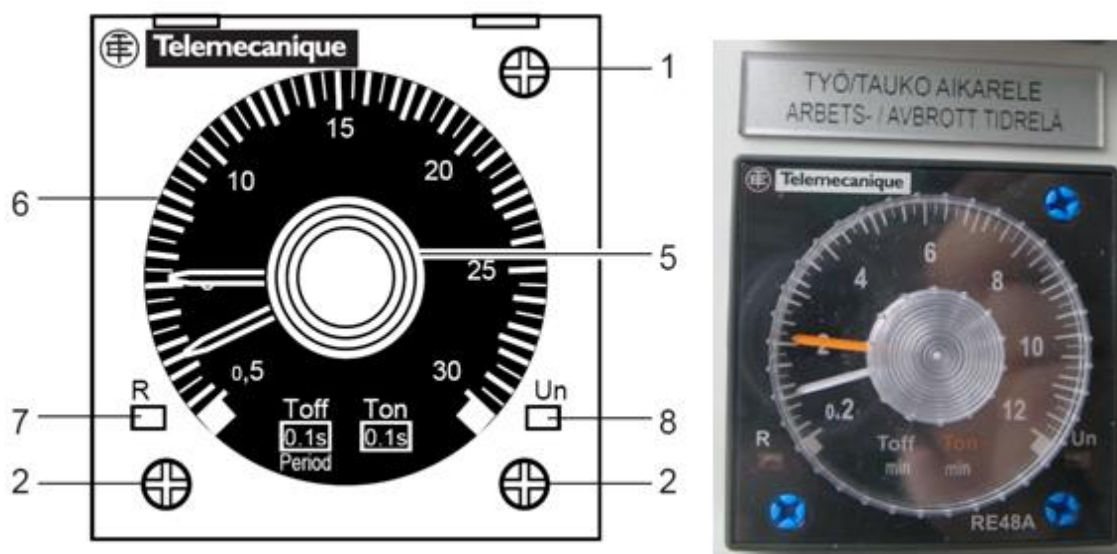

After adjustment check the bottom trough to make sure that the set time are correct, and that the bottom conveyor is empty at least 5 seconds after the run stage has ended. The easiest way to check this is to look through the hatch located on the side opposite to the sampling device.



6.4.4 Setting the burner thermostat

Burner thermostat type: LAE AC1-5TS2RW

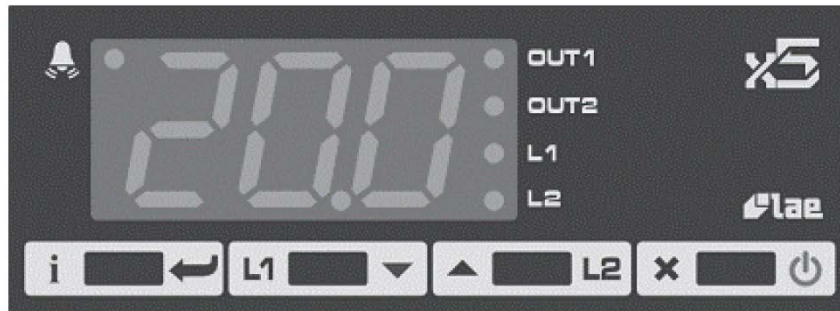

Function: The thermostat is used to adjust the temperature of the air blown into the dryer. The air temperature is displayed in the thermostat screen during the drying process.

Indication: The LED lights located on the right side of the thermostat's numeric display, next to the texts OUT1 and OUT2, show the status of the thermostat keys. OUT1 light on => 1 stage on. OUT2 light on => 2 stage on.

Setting: On the mobile dryer equipped with 1 stage burner (KP 26) the temperature is adjusted by pressing shortly on the **L1** key. The display shows briefly Sp1, and then the set temperature value stored in the memory. Now the value can be changed with arrow keys up **L2** or down **L1** for as long as the value is displayed on the screen. If no key is pressed for 30 seconds, or if the **i** key is pressed, the new value is stored in the thermostat's memory.

On dryers equipped with 2 stage burners (KP26 H and KP-50H) the adjustment process is the same, except the **L2** is now used to set the desired temperature of air from the fan. Press shortly on **L2**, Sp2 is displayed on the screen, now use the arrow keys to set the desired value.

Note that the value of L1 has to be larger than the value of L2.

Example: 1 stage burner:

If the desired drying temperature is 70 °C, set the L1 value to 70. Note that this value only limits the upper temperature value, which means that in case of low outdoor temperature the intake temperature can remain below the set value.

If the burner flame is turned off due to excessively high temperature, the nozzle size needs to be reduced. Otherwise the gasified fuel in the firebox can cause the flame to flare up too strongly.

2 stage burner:

When setting the temperature for a mobile dryer with a 2 stage burner (KP 26H and KP-50H), both temperatures L1 and L2 can be used. The L1 value, adjust the value of the 1 stage flame, and L2 is the value of the 2 stage flame. **The values determine the time when the flame is extinguished.** The idea is to adjust the temperature with the flame of the 2nd stage. The flame of the 2nd stage is extinguished when the temperature is too high. The flame of the 1st stage should be on at all times, it should not be extinguished. If the 1st flame is extinguished, the nozzle is too large and needs to be reduced. The temperature difference between L1 and L2 has to be about 10 °C.

Example. If the desired drying temperature is 80 °C, the L1 value is set to 90 °C and the L2 value is set to 80 °C.

Note that during the drying process the values can vary depending if the outdoor temperature is low.





6.4.5 Setting of the drying thermostat

Type of the drying thermostat: LAE LTR-5TSRE



Function: The thermostat adjusts the switch-over of the dryer from the drying phase to the cooling phase. During the drying process the exhaust air temperature is displayed on the screen. When the drying process starts the thermostat is set to a sufficiently high temperature, e.g. 50 °C.

Indication: The LED light on the top right corner of the thermostat screen, next to the OUT1 text, shows the status of the thermostat. No light => drying, light on => cooling.

Setting: To set the value keep the  key down and at the same time change the value setting up by pressing  or down by pressing . When the  is released, the value is stored in the memory.

Use: As the drying process progresses measure the grain humidity with the moisture meter. When the desired moisture content is achieved read the value displayed on the thermostat screen.

After that set the thermostat according to the instructions above to a value, which is 0.1 °C lower than the value displayed on the screen.

Example: The desired grain humidity is 13%. When the moisture meter displays 13%, the exhaust air temperature value on the thermostat screen is 37.5 °C. The thermostat is setting is adjusted to 37.4 °C.

In this case the dryer shall switch over to the cooling phase, provided that the temperature is still 37.5 °C.

The drying result varies slightly depending on the grain variety, and therefore it is advisable to establish the values for each individual variety experimentally. If the temperature of the air flow from the fan changes considerably, this also affects the drying result. Furthermore, if the outdoor temperature is much lower than the set values, e.g. during night time, the set values are changed vis-à-vis the day settings.

6.4.6 Setting of the feeding apparatus

The feeding amount can be increased or decreased by controlling the frequency converter of the gear motor. If you wish to find out the exact circulation speed, the easiest way to do this is to empty the unit with the feeding apparatus and measuring the time.

Feeder speed	Frequency converter (Hz)	Gear motor	Volume flow rate (m ³ /h)	tn/h
0	7	1400r/min i=41,4 Z1=16 and Z=23	9,4	7,5
5	25	1400r/min i=41,4 Z1=16 and Z=23	23,4	18,5
10	50	1400r/min i=41,4 Z1=16 and Z=23	37,7	30



6.4.7 Setting of the pre-cleaner aspirator

The aspirator setting should be carried out while monitoring the cleaning result. The flap is opened when you hear the sound of grain rustling in the pre-cleaner. The flap is moved slightly towards closed position and left in that position. The cleaning result needs to be checked in order to minimise the quantity of kernels in the debris.

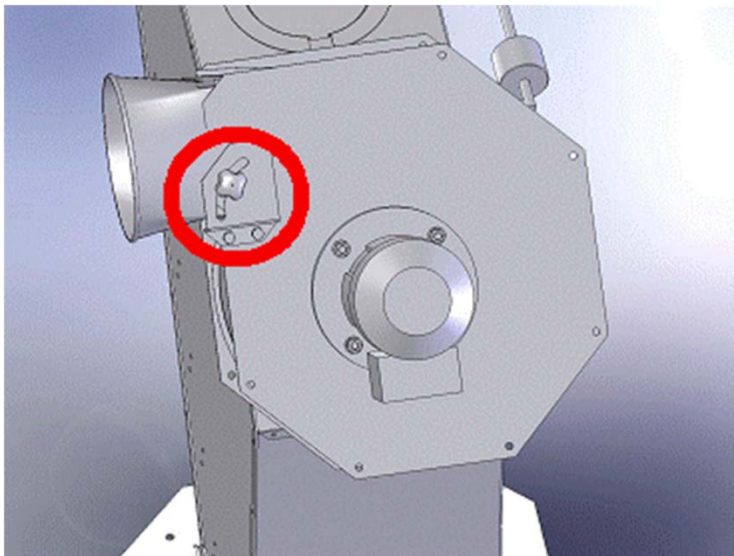

Adjustment of the levelling plate of the pre-cleaner.

The function of the levelling plate is to spread the grain as widely as possible to the intake of the pre-cleaner in order for the pre-cleaning to be as efficient as possible. If the levelling plate is adjusted correctly, it swings slightly during the filling and drying process. If the levelling plate is too heavy, the pre-cleaner can get clogged. If the levelling plate, on the other hand, is too light, it does not level the grain reducing cleaning efficiency.

When adjusting the levelling plate it should be noted that when the weight is moved towards the shaft, the levelling plate gets lighter, and when it is moved away from the shaft, the levelling plate



gets heavier. The appropriate initial setting should be as light as possible, i.e. the position closest to the shaft.



6.4.8 Setting the spreader disc

It is recommended to check the operation of a new dryer for the first few years, and adjust the spreader disc to match particular grain types. When the spreader disc is functioning it is natural that while the dryer is being filled up more grain accumulates at the sides of the grain bin than under the disc. During the drying process, the difference will be halved. If the moisture content of the grain varies considerably over 20%, it is worth checking the working condition of the spreader disc, and make the necessary new adjustments. If however the grain level at the elevator side of the bin is much higher than the manhole, it is advisable to move the disc upward by about 20–30 mm. In the opposite case lower the disc the same amount, i.e. about 20–30 mm. At the final stage of the drying process grain flows through the disc more quickly, and the grain level in the centre of the bin is higher than at the edges.

The spreader disc is adjusted so that the spreader shaft is visible by about 20 – 30 mm from underneath the spreader disc. The guide plate is adjusted such that it is about 40 mm above the bottom of the disc.

By adjusting the holes in the disc, you can also adjust the spreading result. When you close holes, grain will fly on the sides; and when you open up holes, more grain will remain in the middle. The factory setting is 55 m. A change of even 5 – 10 mm to the hole diameter will affect the spreading result. When the seed size is smaller, for example with rapeseed, the holes on the spreader disc must be made smaller.

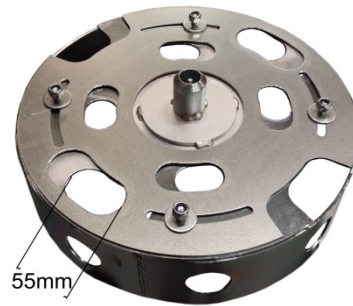
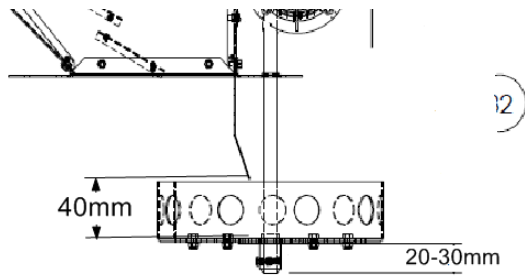

6.4.9 Setting the air flow rate

The air flow can be adjusted with the flap in the suction collar of the furnace fan. The flap is turned towards the closed position, which reduces the air flow. It is not advisable to close the flap completely, unless the batch being dried is particularly small, or if the material is particularly light.



6.4.10 Drying of partial batches

If the batch of grain being dried is significantly smaller than the actual capacity of the dryer, there is the risk that as the drying phase progresses and the grain is dried, the top ridges open up into the grain bin. In this case hot air escapes from the dryer through the opened ridges, while some grain can also drift into the air chambers. In order to dry such batches the dryer is equipped with the partial batch shutters (operated from the rear of the dryer).

When you start drying such partial batch, turn the shutter levers at the rear of the dryer into the “closed” position. Close the furnace intake to reduce the air flow.

In M150k and M180k models there are two hatches at the top part of the drying cells, which act as shutters. These hatches close the top row of ridges of the cell.

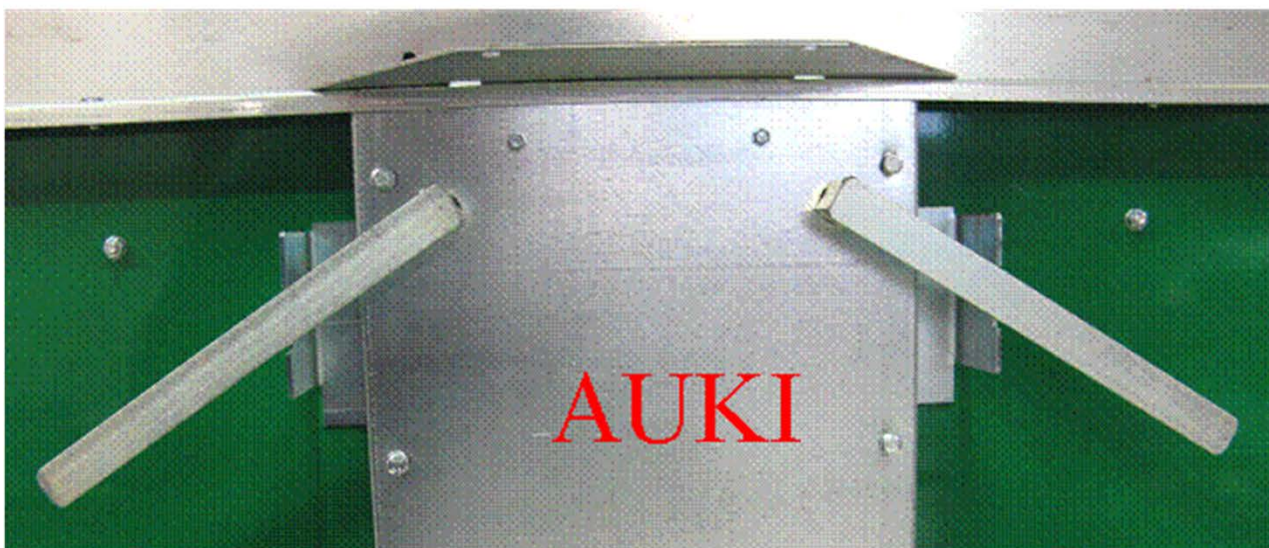

CLOSED
OPEN

Starting from the M205k model the role of the partial batch shutter is performed by the central shut-off hatch, which cuts off the air flow into the top drying cells or cell parts. In larger models there can be as many as two central shut-off hatches on top of each other. These can be used to divide the dryer volume into three sections.

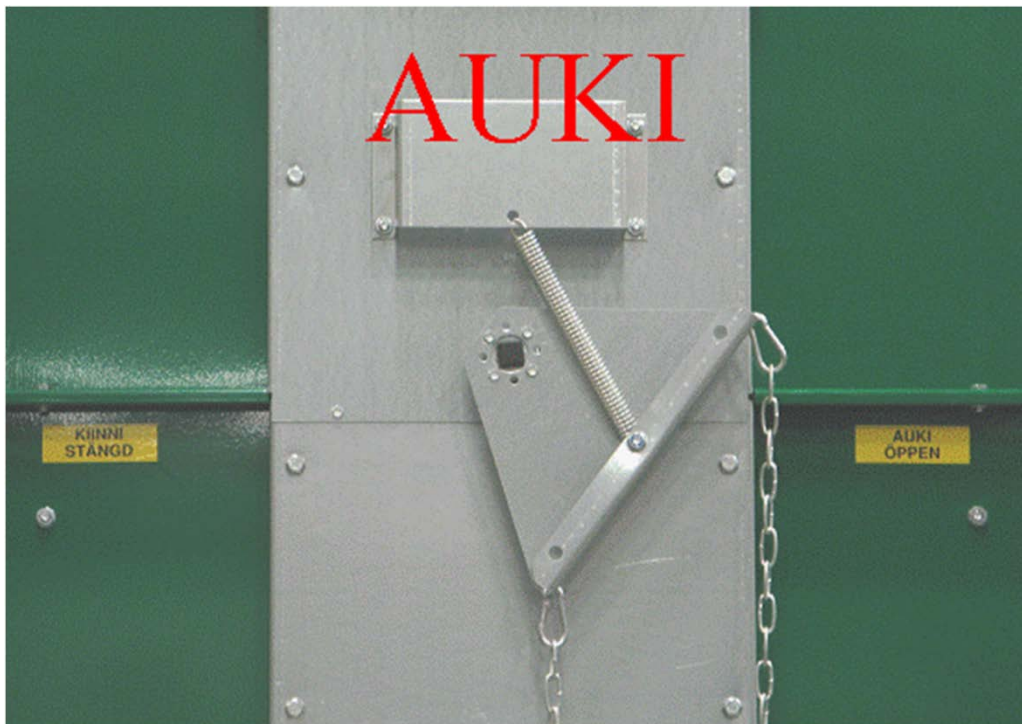

OPEN
CLOSED

6.4.11 Cleaning the central channel after drying a partial batch

When drying a partial batch, some grain may have ended up on the central hatch. Open the central hatch so that the grain would trickle to the bottom of the central channel. Clean the central channel and the base of the furnace; this will prevent the possibility of a fire in the dryer.

6.5 Drying of different grain varieties

Drying of turnip rape

Before starting to dry the turnip rape it is necessary to make the following four basic settings:

- Reduce the feed rate of the feeding apparatus.
- Reduce the main fan air flow rate by about one-half.
- Close the pre-cleaner air flap almost completely, i.e. select the smallest cleaning setting.
- Close the bottom aspirator air flap completely, i.e. select the minimum suction setting or remove the plug.

If the dryer is equipped with a 2 stage burner, the second stage can be completely deactivated. Turn the main burner switch into position 1, causing the temperature to drop. If, however, the burner power is still too high, contact the installer of the burner and have the burner adjusted to a lower efficiency rating by replacing the nozzle.

Drying of peas

The best way to dry peas is to mix it with oats at 50/50 ratio, and otherwise use normal grain drying settings. It is also possible to dry only peas, but depending on the threshing status, it is best to let the peas have 3 – 4 hours of drying heat with minimal rotation. Set the feeder speed to zero, so that the rollers of the feeding apparatus will turn slowly. When the surface of the peas is dry, adjust the feeding speed to normal drying speed.

6.6 Aspects to be noted in respect of hot air dryers

- Removal of dust and debris from the grain during the drying process considerably improves the drying efficiency (pre-cleaner adjustment),
- Whenever possible carry out drying with full batches. This ensures the best energy efficiency.
- Fast feeding rate reduces the grain temperature, while slow feeding rate increases the grain temperature.
- The spreader disc in the grain bin serves to fill the silo evenly ensuring that the thickness of the grain layer in the silo is uniform. This provides for even air circulation and a uniform drying result.

7 Maintenance

The dryer's reliability is a crucial factor for ensuring a successful harvest. Possible malfunctions can cause even significant risks. The best way to avoid risks is to ensure that the unit is maintained properly.



When cleaning the unit, turn the main switch to OFF.

Maintenance and cleaning operations

Maintenance and cleaning operations can be divided as follows:

1. Autumn maintenance, lubrication and cleaning immediately after the drying season.
2. Test running and checks always before the start of a new season.
3. Checks and lubrication during the drying season.

Clean the surfaces, which are not scrubbed clean by circulating grain with a scraper or a brush. At the same time check and clean the internal surfaces of the feeding equipment and the feed rollers, if necessary. Normally the inside of the drying cells does not require cleaning. Clean the exhaust ends of the elements (side air channels) and the exhaust air channel. At the same time check that no debris has drifted into the hot air channel between the furnace and the dryer (there is an inspection door at the centre rear of the unit). Finally make sure that no loosened deposits (debris) is left in the cells. Debris can be removed from the cells by running the fan for a couple of minutes at full capacity. Clean the bottom and top end of the elevator. Carefully check the grain pipes in order to detect any leaks and worn sections.

During the autumn maintenance it is advisable to decide on any possible additions or modifications of the grain pipeline, since the fact of whether they are needed is fresh in the memory. Moreover, the need for any spare parts is also advisable to establish already in the autumn.

Tyres

Check the tyre pressure, if necessary, at least before setting off for a longer distance. At the same time check the tightness of wheel nuts on rims and the fastening of the shafts. It is advisable to protect the tyres against sunlight. The correct tyre pressure is 3 bar.

Bottom trough

Check the sides of the bottom trough and clean, if necessary, through the inspection door at the front. Check the bottom auger and clean, if necessary. Also check the bottom aspirator and clean, if necessary.

Feeding apparatus

Oil level in the feeding apparatus's gear motor does not require checking. You may check the gear motor visually to detect any possible oil leaks in the motor. If a heavy leak is detected, it is advisable to replace the gear.

Lubricate the chains and the lever devices as well as the rotation reversing wheel with engine oil SAE 20...30 or Universal. If necessary tighten the chain, but avoid overtightening it. Lubricate the feeder shaft bearing with grease after the drying season (once a year). Lubrication should be performed carefully to avoid damaging the bearing gaskets.

Elevator

Before the beginning of the drying season and at least during the season check:

- The condition and the tightness of the elevator drive belts
- The fastening and condition of the pre-cleaner
- The tightness of the elevator chain

Do not overtighten the chain. After tightening the elevator has to rotate rather freely, when you turn the larger pulley by hand.

There is a separate maintenance manual for bucket elevators.

Furnace

Clean and de-soot the dryer furnace immediately after the drying season. The explosion /soot hatch is located on the front wall. To open the cleaning hatches in the bottom of the furnace loosen the fastening screws. Before the start of the drying season make sure that there is no debris or dust inside the furnace on the bottom. Vacuum if necessary. De-soot the furnace at least once a year. Do not use any chemicals for cleaning the furnace, other than fuel oil additives recommended by the fuel vendor.

Each time before filling the dryer with the first grain batch test run the dryer as follows: start the dryer with the furnace and shut off the air intake vent. Let the temperature rise until the burner thermostat stops the burner. This way you can check the functioning of the thermostat and burn any dirt in the furnace.

After removing any soot prepare the smokestack for the winter by covering the top of the smokestack or removing the smokestack completely, protecting the stub and the discharge section is turned downward. Open the explosion hatch for winter. It is advisable to cover the drying air intake on the front of the furnace for winter. Before storing the unit for winter fill the oil tank.

Winter storage

Clean the machine after the drying season and store it in a shelter or use a protective cover. Leave all hatches and doors open. Check that the power cable is disconnected and that the protective cover of the main electrical switchboard is properly closed.



If you store grain in the dryer make note of the storage conditions. In the dryer grain can become moist and its quality can drop.

8 Malfunctions

Below is a short description of some automation and troubleshooting related phenomena. Use the list below to check the object of malfunction and possible actions. If the problem is not cured, please contact the maintenance workshop or the manufacturer.

Problem	Cause	Remedy
Emergency stop light NOT ON	<ul style="list-style-type: none"> Any of the emergency stop buttons is pressed down. 	<ul style="list-style-type: none"> Release all the emergency stop buttons by turning or pulling the button. Press the emergency stop reset button so the light will come on again.
The alarm light of the rotation sensor is on	<ul style="list-style-type: none"> The rotation sensor has stopped the machinery. Clogging in the machine or the bottom conveyor auger is not rotating. Chain elevator wraps loose. 	<ul style="list-style-type: none"> Check to find any clogging in the elevator or the bottom conveyor, remove, if any is found. Switch power off and on with the main switch, restart the previous function. If the auger of the bottom conveyor is broken, repair the auger. Check and tighten the belts of the chain elevator as necessary.
The overheat alarm light is on	<ul style="list-style-type: none"> The dryer furnace temperature is too high, the overheat thermostat has stopped the drying process. Possible burner thermostat defect or incorrect burner thermostat setting. 	<ul style="list-style-type: none"> Check the overheat thermostat setting. Check the burner thermostat settings. If the settings are correct, call an electrician and have the thermostats' functions checked.
The machine has stopped.	<ul style="list-style-type: none"> Any of the motor protection relays has tripped. 	<ul style="list-style-type: none"> Check whether the respective fan or conveyor is clogged. Remove the clogging. Is the grain bin too full, the spreader disc has no room for rotating. Empty the dryer of grain. Possible motor defect. The thermal relay has tripped, the motor has broken down. Replace the motor. Reset all the R buttons of the motor protection.
The screens of the digital drying and burner thermostats are dark	<ul style="list-style-type: none"> The glass tube fuse of the control circuit is blown. The digital thermostat is defective. 	<ul style="list-style-type: none"> Check the condition of the glass tube fuse, if necessary replace with a new one. If the defect is not cured even though the fuse is replaced, call an electrician and have the defective digital thermostat replaced.
The burner does not ignite (when the dryer is running). The burner alarm light is off. Note! Ignition time, the pause time of the work /pause time relay.	<ul style="list-style-type: none"> The burner's power switch is in position 0 The burner thermostat settings are incorrect The automatic fuse of the burner has tripped The feeding apparatus's fuses has tripped. 	<ul style="list-style-type: none"> Check the burner's power switch Check the burner's automatic fuse Check the burner thermostat settings Check the drying thermostat settings Check the feeding apparatus's motor protection

The burner does not ignite (when the dryer is running). The burner alarm light is on.	<ul style="list-style-type: none"> • The burner has run out of oil • The fuel filter is clogged • The burner settings are off • Defective burner 	<ul style="list-style-type: none"> • Check oil level • Check the condition of oil hoses • Check the hose arrangement • Check/ replace the filter and the gaskets • Reset the malfunction • If the burner does not start or if the problem reappears, contact the burner maintenance specialist
The elevator motor protection relay trips	<ul style="list-style-type: none"> • The elevator is clogged • The elevator belt is loose 	<ul style="list-style-type: none"> • Check the elevator. Rotate the elevator by turning the belt pulley: <ul style="list-style-type: none"> - If the elevator feels heavy, it is probably clogged. - If the elevator feels light, the chain is probably loose. • Tighten the chain
When the switch is in the filling position, only the pre-cleaner is functioning and if the switch is in the drying position, the furnace fan and the pre-cleaner are functioning, otherwise the dryer does not respond.	<ul style="list-style-type: none"> • The elevator rotation sensor has tripped 	<ul style="list-style-type: none"> • Check the elevator. Rotate the elevator by turning the belt pulley, if the elevator feels heavy, it is probably clogged, and if the elevator feels light, the chain is probably loose. • Tighten the chain • Reset the rotating sensor by switching the power off and on with the main switch.
The earth leakage circuit breaker trips	<ul style="list-style-type: none"> • Any of the switched-on motors is “leaking” 	<ul style="list-style-type: none"> • Call the electrician.
The functioning of the dryer lights during the drying process is abnormal or no power is supplied to the switchboard of the dryer.	<ul style="list-style-type: none"> • The zero phase in the dryer feed is missing • Any of the fuses in the power supply circuit has blown • The earth leakage circuit breaker has tripped • The power cable of the dryer is damaged 	<ul style="list-style-type: none"> • Check the power cable • Check the zero phase • Check whether the fuses in the power supply circuit are intact • Check the main switch of the dryer

 **Note!**

If you have reset any of the motor protection relays, and the relay trips again immediately after the next start-up attempt, and this happens during the warranty period, contact the manufacturer's maintenance workshop and agree on the possible remedy measures. The fault is either in the motor protection relay or the motor connected to it. Therefore it is advisable that the manufacturer's maintenance technician or the local authorised electrical workshop comes and finds the cause of the fault.

9 Concise operating instructions

9.1 In the beginning of the drying season make the following checks

- Tightness and condition of the chains and the drive belts
- The elevator
 - Check the elevator flaps. Replace, if worn.
 - Make sure that the elevator and the dryer are aligned. Measure the distance!
 - Make sure that you have spare belts, flaps and chain links at hand.
- Clean the furnace
 - Cleanliness of the heat channel (drying vault)
 - Get a spare nozzle (spraying angle 80°) and oil nozzle
 - Clean the inside bottom of the furnace and make sure that the burner is clean
- Gear oil (feeding apparatus, spreader disc)
- Lubricate the chains and the feeding machinery bearings
- Check the augers, the grain bin, the drying cells, the feeding apparatus and the bottom trough for cleanliness
- Check the condition of the plastic bottom of the top and bottom conveyors
- Check the condition of the dust and debris pipe and the collection unit (cyclone)
- Test run the dryer to increase its temperature

9.2 Filling

- Close all 6 bottom flaps of the feeding apparatus, cranks locked in the vertical position/ cranked shut
- Remove the shutter plate between the elevator and the feeding auger, connect the feeding auger with the elevator crank
- Turn the divider on the top of the elevator towards the dryer
- Start the filling process by turning the mode selector switch to 2
- Start feeding grain into the hopper
- Monitor the dryer filling process, make sure not to overfill it
- Stop the dryer by turning the mode selector switch to 0, or the level guard stops the machine automatically

9.3 Drying

- Disconnect the feeding auger from the elevator, install the shutter plate between the elevator and the bottom auger
- Turn the divider towards the dryer
- Set the cooling timer to 1–1.5 h
- Check burner control thermostat setting
- Check the drying thermostat setting
- Start the drying process Turn the mode selector switch to 3
- Press the start button The furnace fan starts.
- Monitor the drying process. The dryer and the burner shall start in about 3 minutes after the fan is started.
 - If the on/off timer bypass is selected: The elevator bottom conveyors are running during the entire drying process.
 - The on/off timer is selected: The conveyors run for ca 2 minutes, followed by a ca 1 minute pause, during which time the feeding apparatus gathers grain into the bottom trough. The bottom trough should be emptied during the next running phase. Make sure that the bottom trough is emptied.

- The burner stops when the exhaust air temperature has risen above the dryer thermostat set value. The burner stops and the cooling phase starts.
- Check the humidity of the dried grain batch with a special meter and continue the drying phase, if the humidity level is too high.
- The dryer stops automatically after the cooling time has elapsed.
- Turn the mode switch to 0 and check the final humidity of the dried batch of grain with the special meter.

9.4 Emptying

- Turn the divider away from the dryer to the discharge pipeline. If the discharged batch of grain is to be stored away from the dryer using a pipe/ conveyor arrangement, check that any possible other dividers are set to the proper direction.
- First start the extension conveyors.
- Start the dryer conveyors by turning the mode selector switch to 1 “emptying”.
 - To facilitate the drying process open the feeding apparatus's bottom hatches; by opening first the middle ones from each side halfway. After a while you may open the rest of the bottom flaps.
- At the end stage of the drying process turn the bottom of the hot air channel open. The discharge lever is located between the elevator and the feeding apparatus. Lock the lever immediately after the dryer is emptied.
- Check whether the dryer is empty, and close the bottom flaps.

9.5 After the drying season

- Properly clean and empty the entire dryer, including the elevator.
- Clean the furnace, the burner and the screen
- Lubricate the chains and the feeding machinery bearings
- Leave the bottom hatches open
- Leave all inspection doors open.
- Shut off the fuel oil valves
- Turn the main power switch to 0
- Disconnect the power cable
- Cover the furnace fan intake
- Visual inspection/ maintenance/ cleaning
- Remember: if you store grain in the dryer, consider the winter weather conditions. The batch can become moist and its quality can drop.
- Get the required spare parts in the autumn already and install them, so your dryer will be ready right at the beginning of the next drying season.

10 Technical data

Chain elevator models

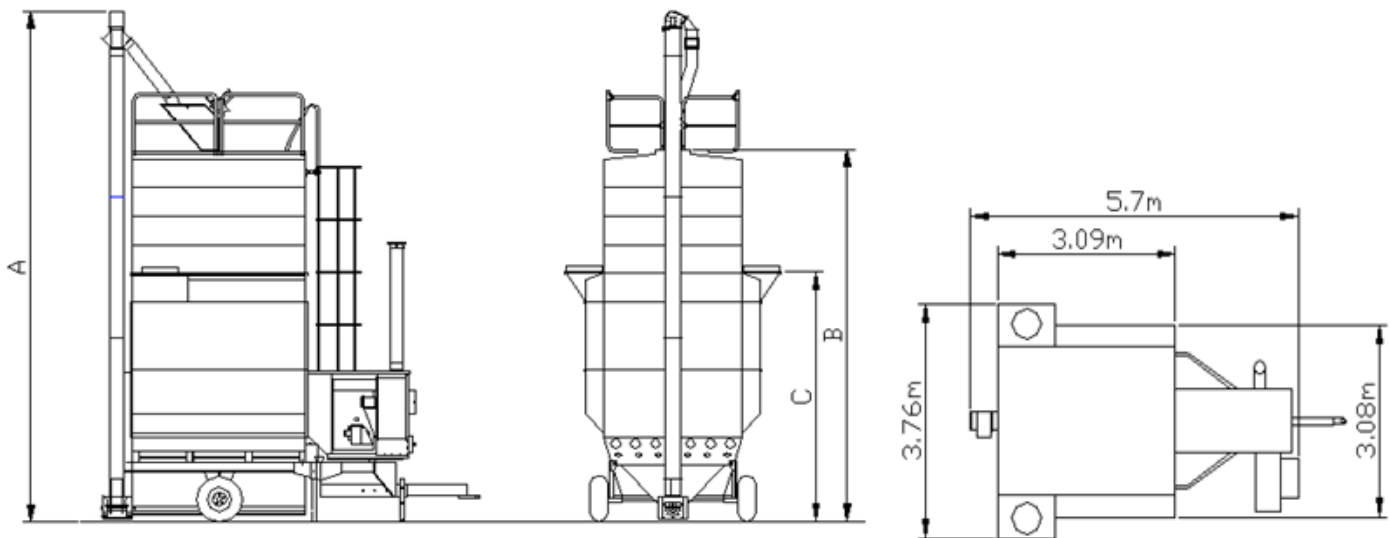

Name	Type	M180k	M205k	M240k
Min. elevator	A [m]	6.8	7.3	7.9
Height	B [m]	4.3	4.8	5.5
Air exhaust	C [m]	2.7	3.2	3.8
Tot. capacity	[m3]	16.3	18.4	21.6
Min. drying batch	[m3]	3.5	6.2	6.2
Dryer machinery	[ton]	5	6	7
Flow during drying	[A]	22	22	27.8
Electric power during drying	[kW]	13.25	15.25	16.8
Furnace		YP-250	YP-250	YP-310
Oil burner		KP-26H	KP-26H	KP-26H
Main fan	[kW]	4	4	7.5
Oil hose	4.0 m	+	+	+
Smokestack	ø200mm 2.0m	1	1	1
Frame		+	+	+
Feeding apparatus		+	+	+
Bottom trough		+	+	+
Bottom conveyor		+	+	+
Drying cell	h=1186 mm	2	2	4
Drying cell	h=500 mm	-	2	-
Oil storage layers		3	3	3
Grain bin service platform		+	+	+
Chain elevator	40ton/h	6.8m	7.3m	7.9m
3-way divider	ø200mm	+	+	+
Grain pipe	ø200mm 2.0m	3	3	3
Pipe bend	ø200 45°	2	2	2
Quick tie	ø200	5	5	5
Pre-cleaner		+	+	+
Sampling device		+	+	+
Ladder		+	+	+
Power cable	63A 10.0 m	+	+	+
Level guard		+	+	+
Control panel		+	+	+
Electrical diagram		+	+	+
Installation manual		+	+	+
Operating manual		+	+	+
Spare parts catalogue		+	+	+

Bucket elevator models

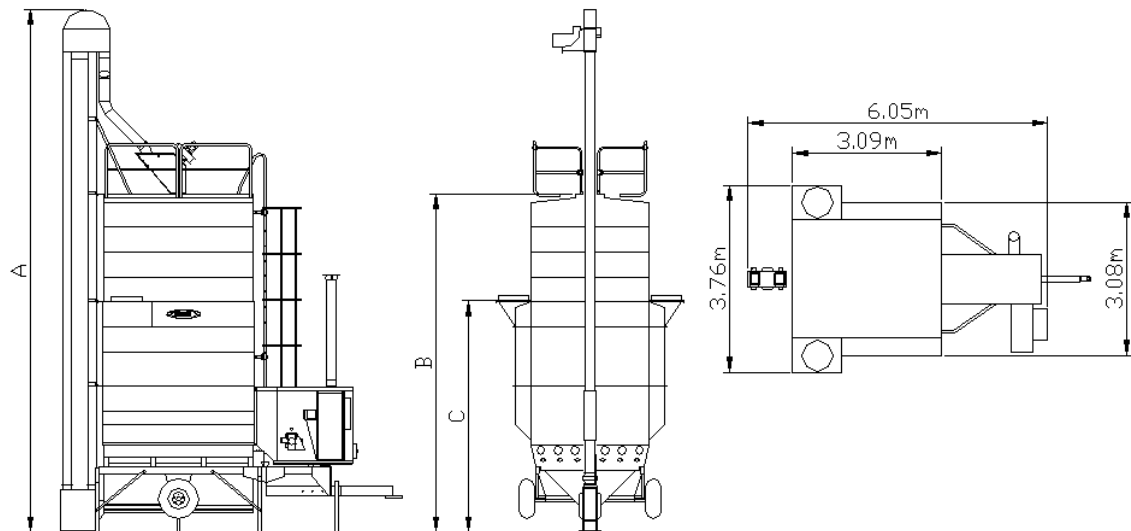

Name	Type	M180k	M205k	M205k	M240k	M275k	M300k	M365k	M420k
Elevator	A [m]	8.25	8.75	8.75	9.5	10	10.5	11.75	13.50
Height	B [m]	4.6	5.1	5.1	5.8	6.3	6.8	8	9.7
Air exhaust	C [m]	3	3.5	3.5	4.2	4.2	4.7	5.4	6.6
Grain volume	[m ³]	16.3	18.4	18.4	21.6	25.1	27.2	33.9	39.5
Min. drying batch	[m ³]	3.5	6.2	6.2	6.2	6.2	6.2	6.2	21
Dryer machinery	[ton]	5	6	6	7	7.5	8	8.5	9.4
Flow during drying	[A]	22.8	22.8	26.6	30	30	43.1	44.7	50.1
Electric power during drying	[kW]	13.8	13.8	16.1	17.3	18.1	26	27	27.6
Bucket elevator	[ton/h]	60	60	60	60	60	60	60	60

Name	Type	M180k	M180k	M205k	M205k	M240k	M275k	M300k	M365k	M420k
Furnace YP-		250	310	250	400	400	400	500	500	500
Oil burner		26H	26H	26H	50H	50H	50H	50H	50H	50H
KP-										
Main fan	[kW]	4	4	4	5.5	7.5	7.5	11	11	11
Channel aspirator	[kW]	-	-	-	-	-	-	2x2.2	2x2.2	2x2.2
Oil hose	4.0 m	-	-	-	-	-	-	-	+	-
Feeding apparatus		+	+	+	+	+	+	+	+	+
Pre-cleaner		+	+	+	+	+	+	+	+	+
Sampling device		+	+	+	+	+	+	+	+	+
Frame		+	+	+	+	-	-	-	-	-
Frame (reinforced)		-	-	-	-	+	+	+	+	+
Bottom trough		+	+	+	+	+	+	+	+	+
Bottom conveyor with own motor		+	+	+	+	+	+	+	+	+
Drying cell	h=1186mm	2	2	2	2	4	4	4	6	8
Drying cell	h=500 mm	-	-	2	2	-	-	2	-	-2
Smokestack	ø200mm 2.0 m	1	1	1	2	2	2	2	2	
3-way divider	ø200 mm	+	+	+	+	+	+	+	+	+
Power cable	63A 10.0 m	+	+	+	+	+	+	+	+	+
Control		+	+	+	+	+	+	+	+	+



panel										
Oil storage layers		3	3	3	3	3	4	4	5	+
Grain bin service platform		+	+	+	+	+	+	+	+	+
Ladder		+	+	+	+	+	+	+	+	+
Grain circulation pipes	ø200 mm 2.0 m	+	+	+	+	+	+	+	+	+
Level guard		+	+	+	+	+	+	+	+	+
Electrical diagram		+	+	+	+	+	+	+	+	+
Installation manual		+	+	+	+	+	+	+	+	+
Operating manual		+	+	+	+	+	+	+	+	+
Spare parts catalogue		+	+	+	+	+	+	+	+	+



12 Declaration of conformity

**Vaatimuksenmukaisuusvakuutus
Declaration of conformity
Garanti av motsvarighet**

ID: D03734



Valmistaja, Manufacturer, Tillverkare

Yrityksen nimi, Name of the company, Företaget namn:	<i>Mepu Oy</i>
Osoite, Address, Adress:	<i>Mynämäentie 59, 21900 Yläne, Finland</i>

Laite, Machine, Maskin

Kuvaus, Description, Beskrivning:	<i>Vaunukuivaamo, Mobile dryer, Mobil tork</i>
Tyypimerkintä, Type, Typmärkning:	<i>MXXXX (xxx=koneen koko, xxx=size of the machine, xxx=storleken av maskinen)</i>
Sarjanumero, Serial number, Serienummer:	<i>58532-</i>

Directiivit ja standardit, Directives and standards, Direktiv och standarder

Vakuutamme, että laite täyttää direktiivit, We hereby declare that the equipment complies with the directives, Vi förklarar härmed att utrustningen uppfyller direktiven:	<i>2006/42/EC 2004/108/EC 2006/95/EC</i>
Standardit (tai niiden osia/kohtia) joita on sovellettu, Standards (or parts/clauses) that have been used, Standarder (eller delar/paragrafer) som har använts:	<i>EN 349 + A1 EN ISO 13849-1 EN ISO 13850 EN ISO 13857 EN 60204-1:2006 EN 61439-1 EN 61439-2</i>

Tekninen tiedosto, Technical file, Tekniska fil

Laatija, Author, Författaren:	<i>Iiro Uusi-Salava</i>
Osoite, Address, Adress:	<i>Mynämäentie 59, 21900 Yläne, Finland</i>

Allekirjoitus, Signature, Namnteckning

Päiväys, Date, Datum:	<i>12.6.2015</i>
Paikka, Place, Platsen:	<i>Yläne</i>
Allekirjoitus, Signature, Namnteckning	<i>I: U.S. Iiro Uusi-Salava</i>
Asema, Position, Status	<i>Tuotekehityspäällikkö, R&D Manager, Produktutvecklingschef</i>



Mepu Oy:n huoltopalvelu:
Puh. (02) 275 4444 / Huolto
Fax. (02) 256 3361
E-mail: service@mepu.com

Mepu Oy service:
Tel: (02) 275 4444 / Maintenance
Fax: (02) 256 3361
E-mail: service@mepu.com

MEPU Oy
Mynämäentie 59, 21900 Yläne, Finland
p. +358(2) 275 4444, mepu@mepu.com
www.mepu.com