

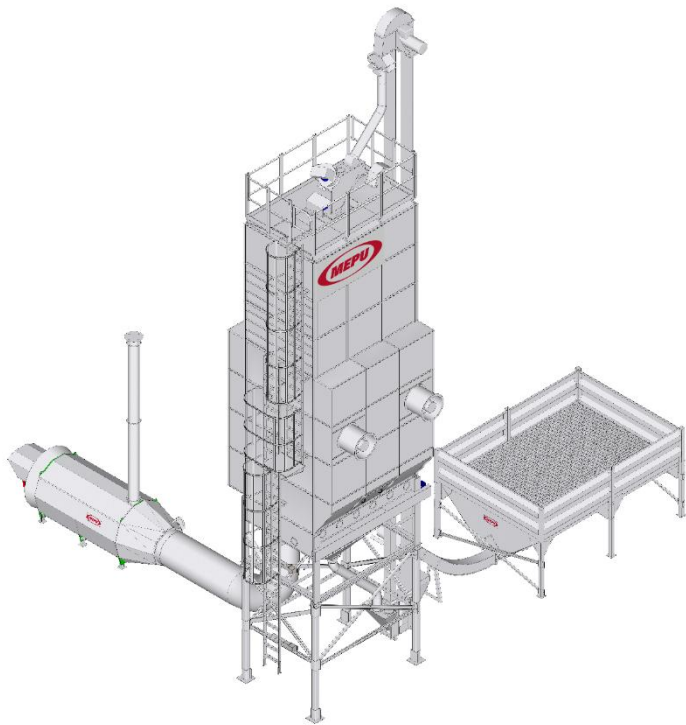

PART OF ARSKA GROUP

USER GUIDE



GRAIN DRYER USER GUIDE S / M / C - SERIES

D16694_EN



PART OF ARSKA GROUP

Contents

1.	INTRODUCTION	4
2.	WARRANTY AND WARRANTY CONDITIONS	5
3.	SAFETY	6
3.1.	GENERAL SAFETY INSTRUCTIONS	7
3.2.	IMPORTANT SAFETY INSTRUCTIONS FOR DRYER USER	8
3.3.	FIRE SAFETY	10
4.	BASICS OF GRAIN DRYING	11
4.1.	KEEPING QUALITY OF GRAIN	11
4.2.	OPERATING PRINCIPLE OF A GRAIN DRYER	11
4.2.1.	<i>Hot-air drying</i>	11
4.2.2.	<i>Cooling</i>	13
4.2.3.	<i>Economical drying</i>	13
5.	DESCRIPTION OF THE GRAIN DRYER PROCESS	14
5.1.	BATCH DRYING	14
6.	TECHNICAL SPECIFICATION	15
6.1.	DRYER MACHINERY	16
6.1.1.	<i>GRAIN STORAGE</i>	18
6.1.2.	<i>DRYING CELLS</i>	18
6.1.3.	<i>FEEDING APPARATUS</i>	19
6.1.4.	<i>BOTTOM CONE</i>	25
6.1.5.	<i>AIR INTAKE AND EXHAUST CASINGS</i>	26
6.1.6.	<i>AIR CASING ADJUSTMENT SHUTTER</i>	27
6.2.	BASE	28
6.3.	LOADING OF THE GRAIN INTO THE DRYER AND UNLOADING	28
6.3.1.	<i>GRAIN CHANNELS</i>	28
6.3.2.	<i>CONVEYORS</i>	29
6.4.	RECEIVING OF GRAIN	29
6.5.	PRE-CLEANER	29
6.6.	GRAIN SPREADER	29
6.7.	AIR DUCTS	30
6.8.	FANS	30
6.9.	LADDERS AND STEPS	30
6.10.	MAINTENANCE PLATFORMS	30
6.11.	ELEVATOR	31
6.12.	HEAT SOURCE	31
7.	COMMISSIONING	32
8.	MAINTENANCE DURING THE DRYING SEASON	33
9.	MAINTENANCE AFTER THE DRYING SEASON	34
10.	TROUBLESHOOTING	35
11.	DRYING OF DIFFERENT GRAIN VARIETIES	37
12.	EC DECLARATION OF CONFORMITY OF THE MACHINERY	38

1. INTRODUCTION

This manual contains the operating instructions for Mepu grain dryers (S-, M- and C-series). The manual provides information about the key components of grain dryers but focuses on the functioning of the dryer machinery. Manuals for other parts of the grain dryer are delivered separately.

The type designation of the dryer machinery is the following:

DRYER TYPE	LENGTH OF THE DRYER MACHINERY [m]	GRAIN VOLYME OF THE DRYER MACHINERY [m ³]
S = stationary dryer	2	15-
M = mobile dryer	3	20-
C = continuous flow dryer	4	25-
	5	31-



S2-15

In order to ensure efficient functioning and safe installation of the dryer, carefully read this manual. Make sure that everyone else in the work zone is familiar with all safety measures. Keep this manual at hand and review it always with any new employees.

Call your local distributor or dealer if you need assistance or additional information.

2. WARRANTY AND WARRANTY CONDITIONS

The product is intended for professional use. Installation, use and maintenance of the equipment require normal general knowledge and skills related to machines and equipment that a professional farmer should presumably possess.

Warranty conditions

The dryer machinery is covered by a 12-month warranty from the commissioning date, but the maximum duration of the warranty is 14 months from the invoice date of the Goods. Mepu Oy cannot be held responsible for any defects discovered after the aforementioned time limits. Mepu Oy undertakes to eliminate any design, raw materials, or workmanship-related faults in the Goods through repair or replacement. Mepu Oy is not responsible for any direct or indirect damages or losses.

The warranty does not cover faults arising from materials provided by the Purchaser or structural solutions specified or set out by the Purchaser. Moreover, Mepu Oy's warranty and liability for faults do not cover minor faults and deviations that exert no substantial influence on the use and functionality of the dryer machinery. The warranty does not cover faults caused by any factors discovered after transfer of the burden of risk. For example, the warranty does not cover faults caused by failure to comply with the use and storage conditions specified for the Goods or instructions for use, or improper use of the Goods. In this connection, inter alia, feeding the equipment with material significantly differing from the average quality of the material processed or with material that does not belong in the equipment is also considered improper use, for example, feeding of grain dryers with material of significantly higher-than-average moisture content and / or of significantly higher-than-average weed and / or other impurities (such as rocks, dirt or foreign objects) content, or feeding of material containing large rocks onto the conveyors. The warranty does not cover faults arising from inadequate maintenance or incorrect installation carried out by the Mepu Oy, or faults arising from modifications or repairs performed without the Seller's written consent. Moreover, the warranty does not cover normal wear and tear.

Whenever a fault is detected, the Seller is required to submit a written fault report without undue delay. The fault report must describe the nature of the fault. If there is reason to assume that the fault could cause additional damage, use of the Goods must be discontinued and the fault report submitted immediately. Otherwise, the Purchaser shall lose its right to submit claims regarding damages that could have been avoided by immediate termination of the use and / or submission of a fault report.

If the Purchaser has reported a fault and it is determined that the Goods are free of faults covered by Mepu Oy's warranty, Mepu Oy shall have the right to demanding compensation for the work and expenses incurred because of the fault report. If intervention with Goods other than those delivered by Mepu Oy is required in order to repair a fault, Mepu Oy shall not be responsible for the related works and expenses.

If a fault in some component has been eliminated, Mepu Oy shall be liable for the repaired or replaced component in the same way as for the original delivery for 12 months. However, Mepu Oy shall not be liable for faults in any component of the Goods or damage caused by the Goods for longer than 36 months from the beginning of the original liability period.

3. SAFETY

Important: *The general safety section contains instructions related to all safety routines. Instructions pertaining to certain specific subjects (for example, assembly-related safety) can be found in the respective section. Always read all the instructions, not only the summary of safety practices, before commencing any operations with the equipment.*

YOU are responsible for **SAFE** use and maintenance. **YOU** need to make sure that you and any other person working in the vicinity of the product are aware of all procedures and information related to **SAFETY** and contained in this manual.

Remember - **YOU** are the key to safety. Good safety practices will keep you and the people around you safe. Make these procedures a functional part of the safety program.

- The user or operator is responsible for reading, understanding, and following the manual's safety instructions. All accidents can be avoided.
- The equipment owner needs to provide guidance and go through the instructions prior to commissioning of the equipment and at least once a year with all the employees before they are allowed to use equipment. Untrained users / operators expose themselves and bystanders to the risk of serious or fatal injuries.
- Use the equipment only for its intended purpose.
- Do not modify the equipment in any way. Unauthorized modifications may impair the functionality and / or safety and affect the product's service life. Any modification of the product voids the warranty.
- Keep children and unauthorized persons away from the work area.
- Keep first aid means available at all times and make sure you know how to use them.
- A fire extinguisher must be readily available at the work site. Keep it in a visible place.
- Use proper personal protection equipment:



- hard hat
- work gloves
- anti-slip safety shoes
- safety goggles
- hearing protection
- coveralls



- Electrical equipment: Before electrical equipment maintenance, adjustment or repair, disconnect the plugs, set all switches to the neutral or OFF position, stop the motors, remove the ignition key or disconnect the power supply, and wait for all moving parts to stop.
- Comply with good work area practices:
 - Keep the usage area clean and dry.
 - Make sure the electrical outlets and tools are properly grounded.
 - Use adequate lighting for works performance.
 - Consider SAFETY! Work SAFELY!



3.1. General safety instructions



The safety-related warning sign marks important safety instructions on the product and in the manual. If you see this symbol, consider the possible risk of serious or fatal injury. Follow safety instructions.

DANGER



Indicates an imminent danger to life that may result in serious or fatal injuries unless avoided.

WARNING



Indicates a potential danger to life that may result in serious or fatal injuries unless avoided.

CAUTION



Indicates a dangerous situation that may result in minor or moderate injuries unless avoided.

NOTE

Indicates a potentially dangerous situation that may result in proper damage unless avoided.

3.2. Important safety instructions for dryer user

Mepu grain dryers have been designed to be as safe as possible. However, depending on local conditions, installation, and equipment configuration, the user needs to consider some safety precautions when using or servicing the device.



Risk of falling

The grain dryer is high, and therefore you should move carefully on maintenance platforms and on ladders. Be particularly cautious when working on the roof in rain, or if the roof is covered with ice. Regularly clean the maintenance platform and ladders and check their condition. The service hatch of the grain bin must always be kept shut. If you need to go into the grain bin, be extremely cautious and have another person nearby to ensure that the work can be done safely.



Unexpected start

Before performing any maintenance operations, always turn off the main power of the grain dryer. Get to know the operation of dryer control.



Risk of being crushed

Keep all safety covers of the dryer machinery, the conveyor and the elevator in place. Always turn off main power of the grain dryer before starting any maintenance procedures.



Risk of hearing damage

The sound pressure level of dryer exceeds 80dB(A) in several locations. Position the equipment such as to minimize noise emissions. Use earmuffs. The major sources of noise are:

- Fans
- Conveyors. In particular, chain conveyors make very strong noise when running empty. Avoid running the conveyor empty.
- Filling the dryer machinery.



Risk of suffocation

Spaces with no oxygen can form in the grain bin. If you need to go into the grain bin, first ventilate the unit carefully. Never go inside the grain bin without having another person to ensure your safety.



Hot surfaces

Surfaces located near the heat source can be hot. The pipe on heat sources equipped with heat exchangers is hot. When installing the equipment, try to make contacting the pipe impossible, or protect the hot surfaces.



Beware of fuel damage

Regularly check the fuel hoses and couplings of gas and oil burners.

PART OF ARSKA GROUP

**Additional lighting**

The drying season is at the end of summer, when evenings and nights are already dark. To ensure work safety make sure that there is enough lighting around the grain dryer.

**Risk of a traffic accident**

Grain is delivered to and from the grain dryer with large vehicles. Make sure that everyone working in the area is familiar with traffic routes. Make sure that drivers have unobstructed view of the traffic route.

**Instructions**

Read all the instructions on use of the grain dryer equipment prior to installation and commissioning.

PART OF ARSKA GROUP

3.3. Fire safety



The most common safety risk associated with grain dryer is fire. In addition to significant property damage fire can cause personal injuries.

These key measures help to reduce the risk of fire:

1. Make sure that air supplied into the heat source of the grain dryer is clean. Prevent debris from getting into the dryer air.
2. Make sure that exhaust air from the grain dryer is not mixed with the heat source intake air.
3. Guide the air from the pre-cleaner and the dust fan into the cyclone. Guide the debris from the cyclone into a contained section.
4. During the drying season regularly clean the machinery and the heat source carefully. Take into consideration the requirements of different grain varieties in respect of cleaning.
5. After the end of the season carefully clean the dryer. Pay particular attention to the cleanliness of the heat source and the hot air ducts.
6. Ensure electrical safety.
7. Never store or keep ignition sources near the grain dryer.
8. Keep the surroundings of the grain dryer clean and tidy.
9. Check and clean the heat source before the beginning of the season.

Firework

Performing any firework in the grain dryer requires extreme caution. Even the smallest spark can cause extensive damage.

In particular, carefully clean the surroundings of the work zone of any dust and debris. Appoint another person to monitor the environment. Keep fire extinguishing appliances at hand near the work zone.

Fire extinguishers

- In Finland there must be at least 2 checked and operational 6 kg manually operated fire extinguishers available in immediate vicinity of the grain dryer during the drying season
- Find out the local requirements established for fire extinguishing appliances.

4. BASICS OF GRAIN DRYING

4.1. Keeping quality of grain

The keeping quality of grain depends mainly on two aspects:

1. **Microbial processes.** In order to live micro-organisms (e.g. fungi, bacteria and viruses) need nutrients, water and heat.
2. **Grain's enzyme activity and respiration.** Grain is a living material even after it's harvested. Kernels use their carbohydrate reserves and produce carbon dioxide, humidity and heat.

Therefore, moisture content of grain and warehousing temperature significantly affect the keeping quality of grain. The longer it is intended to store grain, the lower should the grain moisture content be, and care must be taken to ensure that e.g. sunlight does not heat the walls of the grain storage excessively.

Under the weather conditions in Scandinavia and the northern hemisphere, the moisture content of grain after harvesting varies typically between 15-45%, while the atmospheric humidity is between 70-90%. In such conditions the sufficiently low grain moisture content figures are rarely achieved on the field.

Therefore, grain has to be handled applying various methods in order to improve its keeping quality. The established handling methods include various drying techniques and – in a smaller scale – freezing of grain.

4.2. Operating principle of a grain dryer

The function of grain dryers is based on mixing air and grain by leading strong currents of air through the grain being dried. Air currents evaporate water from kernel surfaces and lead it out from the dryer. The evaporation process causes the drying air temperature to drop

4.2.1. Hot-air drying

The dehumidification process can be intensified by increasing the drying air temperature, in which case there is more energy available for evaporating water and, on the other hand, air can carry larger quantities of vaporized water. At the same time the kernel temperature increases, which promotes migration of moisture to the to the kernel surface

During the hot-air drying process it is important to ensure that the drying temperature is sufficiently low. If the kernel temperature gets too high, the germinability and baking properties of grain are affected negatively. In case of some varieties high temperatures could cause hardening of the kernel surface, which significantly reduces migration of moisture from inside kernels to the surface. The maximum grain temperatures vary by varieties and depending on the intended use of the grain.

	Seed grain	Bread grain
Variety	Max °C	Max °C
Sunflower	43	65
Durra	43	82
Peas	43	65
Millet	43	87
Oats	43	71
Corn (yellow)	43	99
Corn (white)	43	99
Barley	43	71
Rice	43	60
Rye	43	87
Turnip rape	43	71
Mustard	43	71
Soy	43	71
Buckwheat	43	71
Wheat	43	87

Indicative grain temperatures

Seed grain	+50...+60 °C
Bread grain	+60...+70 °C
Fodder grain	...+110 °C

Indicative drying air temperatures

It is important to note that grain temperature and drying temperature are two different things. The temperature of drying air can be much higher than the grain temperature, because a kernel is in the hottest part of the air flow for just a brief moment, as it moves continuously downward in the drying cells.

The drying air temperature depends on the equipment used (the size of the equipment, furnace and fan capacities, length of ducts, etc.) and the weather conditions during the drying process. It is advisable to take these issues into consideration when designing the grain dryer and dimension the equipment optimally.

The homogeneity of drying quality can be improved by circulating the grain during the drying process. When selecting the circulation rate, it is advisable to remember a couple of facts:

- slow circulation rate can cause grain to heat locally
- high circulation rate increases grain breakage

In batch dryers, generally the circulation rate of the batch is one cycle per hour.

In continuous flow dryers grain flows through the equipment only once.

If the moisture content in dried grain is high, there is the risk that the kernel structure is damaged, as the surface dries faster than the inside. In this case drying is often carried out as a multi-stage process, where grain humidity evens out between individual drying stages. It is advisable to reduce the moisture content by at most six percentage points during one drying stage.

There are generally two ways of carrying out multi-stage drying:

1. In **batch dryers** the grain bin above the drying cells is sufficiently large, so that the variations in humidity have time to even out.
2. In **continuous flow dryers** grain is moved to a ventilation silo or a separate dryer intended for such purpose, where the moisture contents variations can even out. After the moisture content has evened out (tempering phase) grain is delivered back into the basic dryer.

4.2.2. Cooling

After the drying phase grain has to be cooled down to almost the outdoor temperature before it is stored in the warehouse.

There are several methods that can be used for cooling:

1. In **batch dryers** the grain batch is circulated with the main fan is running and the heat source is turned off. The recommended cooling time is one hour
2. In **continuous flow dryers** the lower drying cells are used for cooling the grain. The recommended share of the cooling section vis-à-vis the total capacity cells is 1/3.
3. In a **cooling silo** grain is cooled down in a separate ventilation silo. The size of the silo and the fan capacity define the required cooling time. With cooling silos it is possible to increase the dryer capacity, because the cooling phase is left out. A cooling silo may also be used for cooling grain from a continuous flow dryer.

4.2.3. Economical drying

The fuel prices can vary rather significantly, but generally the most costly part of the hot-air drying process is heating the drying air

There are a couple of things that should be kept in mind when looking for the most economical drying option:

1. Optimise the air current intensity and the temperature. The efficiency of drying is the highest when the exhaust air does not quite have time to form condensate on the exhaust duct surfaces. Finding this point requires experimenting, because it is influenced to a large extent by the product being dried as well as the local conditions.
2. Do not over dry. Obtaining very low moisture content levels requires, in relative terms, much more energy than higher moisture content levels. Stop the drying process before you have reached the moisture content level for storage, and remove the last part of the humidity by cooling.
3. Avoid drying when the relative humidity of outdoor air is high, for instance at night and in rain.
4. Dry only full batches in a batch dryer.
5. Keep the heat source in a good and well maintained condition.
6. Keep the grain dryer in a good and well maintained condition.
7. Do not dry debris. Run the pre-cleaner at its maximum efficiency.

5. DESCRIPTION OF THE GRAIN DRYER PROCESS

The grain drying process can be carried out using one of the two different methods: batch drying and continuous flow drying.

5.1. Batch drying

Batch drying is a method that is suited for smaller grain quantities, for varying varieties / qualities – in particular – for drying of moist grain.

1. Filling the dryer machinery. The main fans be kept running in the limited mode. By limiting the air current, it is possible to reduce the quantity of kernels dropping into the air intake channel and, on the other hand, air is circulated in the equipment during the filling process. The heat source may be switched on at a limited temperature when the drying cell is covered by grain
2. Drying. Grain is circulated in the equipment until the target humidity is achieved. The target humidity can be checked e.g. by measuring the exhaust air temperature or by directly measuring the humidity of grain.
3. Cooling. Grain is circulated during the period set by the controls.
4. Emptying.

Stage	Charging elevator	Discharging elevator	Top conveyor /pre-cleaner /spreader	Feeding apparatus	Bottom auger	Heat source	Fans
Filling the dryer equipment	ON	OFF	ON	OFF	OFF	OFF	OFF (1/2 ON)
Starting the drying process	ON	OFF	ON	ON	ON	ON	ON
Continuous flow drying/cooling	ON	ON	ON	ON	ON	ON	ON
Emptying	OFF	ON	OFF	ON	ON	OFF	OFF

The state of different sections of the grain dryer in case of continuous flow drying.

6. TECHNICAL SPECIFICATION

This section discusses the most commonly used parts and phases of the grain dryer. The content of the delivery varies by project, and therefore this section only contains a general description of the different parts of the grain dryer and their purpose. This section focuses on the functioning of the dryer machinery manufactured by Mepu. Manuals for other parts of the grain dryer are delivered separately.

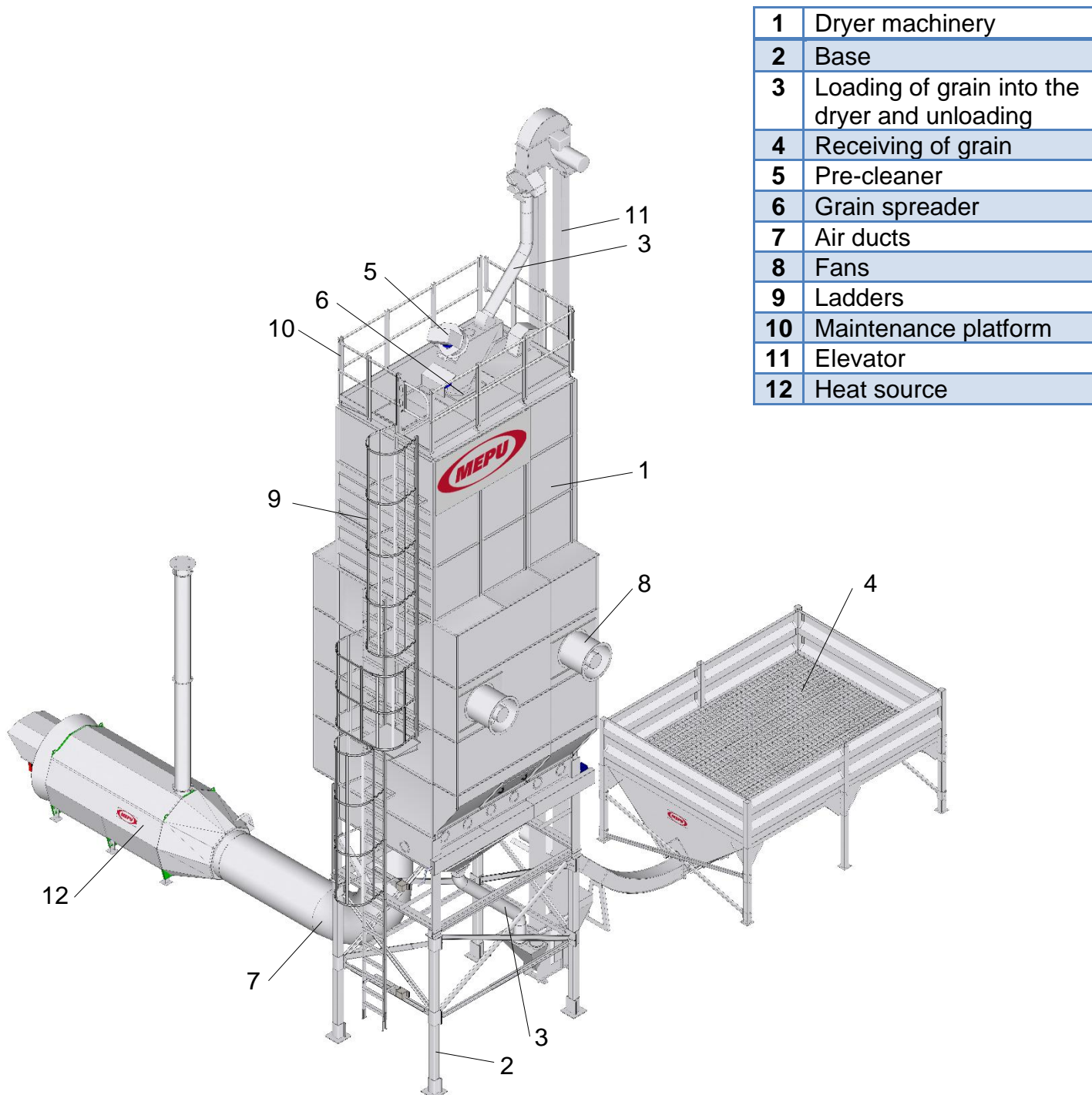

Figure 1. Key parts of a grain dryer

6.1. DRYER MACHINERY

The dryer machinery is the part of the dryer where grain is mixed with air, i.e. is being dried. The dryer machinery can also be used for storage of grain, in which case it is necessary to pay particular attention to watertightness during the dryer's assembly process.

The dryer machinery of a Mepu grain dryer consists of modular parts, and by combining these parts it is possible to get the desired capacity, the total volume, the bottom size as well as any other desired properties.

The length of a Mepu (Z) starts from two meters (2,0m) and grows by adding sections of one meter (1,0m). The width of the bottom (X) is two meters (2,0m). The height of the equipment (Y) grows by adding sections of one meter (1,0m).

1	Grain storage
2	Drying cells
3	Feeding apparatus
4	Bottom cone
5	Air intake casing
6	Air exhaust casing

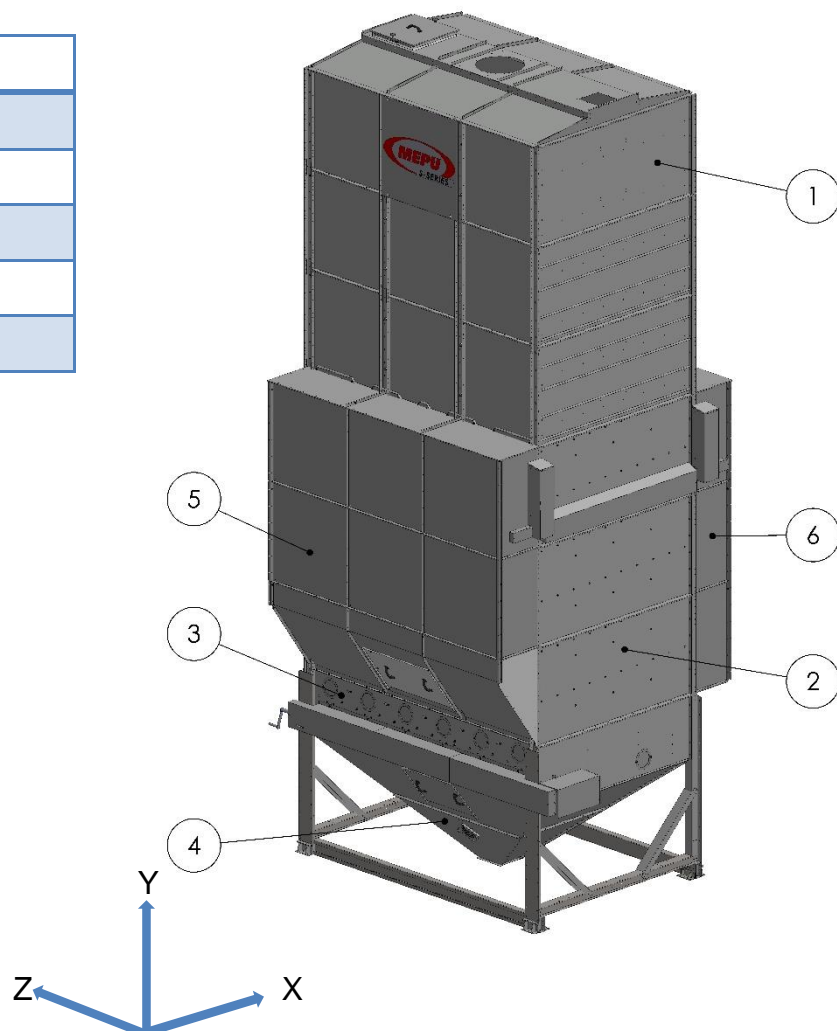

Figure 2. Parts of the dryer machinery

Material and surface treatment

The parts of the dryer machinery are mainly made of hot galvanized steel.

1. The thickness of the zinc coating of the steel sheet parts (sheet thickness 1-3mm) is 20 µm. The sheets are cut after galvanization, which means that there is less zinc around the cut edges. The zinc coating at the cut edge is gathered up on the cut surface. The impact of this reduces as the material thickness increases, and over time corrosion will be formed on the surface of the cut.
2. Welded parts and frame structures are made of steel with thickness over 3mm. The surface coating method is hot dip galvanization. The zinc coating thickness of these structures is 60 µm.
3. Some parts are electrolytically zinc-plated due to higher tolerance requirements, in which case the coating thickness is just 6 µm. These parts are protected against weather conditions with other methods.

Atmospheric corrosivity category	Steel sheets [a]	Frame structures [a]
C2	28-200	85-600
C3	10-28	28-85

Rate of zinc thickness loss in years for different atmospheric corrosivity categories. Keeping surfaces clean can significantly affect the durability of the zinc coating.

Atmospheric corrosivity categories	Exterior	Interior
C2	Mostly rural areas.	Unheated buildings where condensation may occur.
C3	Urban and industrial atmospheres, moderate sulphur dioxide pollution. Coastal areas with low salinity.	Production rooms with high humidity and some air pollution.

Explanation of atmospheric corrosivity categories.

Equipment decommissioning and scrapping

Material	Primary type of waste
Metal parts and power cables	Scrap metal
Electric motors, sensors electrical centre	Metalliromu
Sähkömoottorit, anturit, sähkökeskus	Electrical and electric waste
Plastic parts	Plastic
Manuals and other paper documents	Paper



At the end of a product's life cycle, the equipment and primarily recycled. Study local regulations and comply with them.

6.1.1. GRAIN STORAGE

The main function is to keep the grain surface in the equipment at a sufficient level. During the drying process moist grain first swells a bit, and then starts to shrink, as the moisture content drops. If during the drying process the grain level in the grain storage drops below the top ridges of the drying cells, air starts flowing around the grain layer. In this case the efficiency of the drying process drops significantly.

By increasing the height of the grain storage, it is possible to increase the grain capacity of the dryer machinery with insignificant costs.

In a batch dryer the grain storage works as a space for balancing the grain's humidity while the grain is circulating in the equipment.

6.1.2. DRYING CELLS

In Mepu grain dryers the drying process takes place in mixed flow drying cells. These cells feature alternately placed triangular air ducts, which lead hot air in and moist air out of the dryer cell.

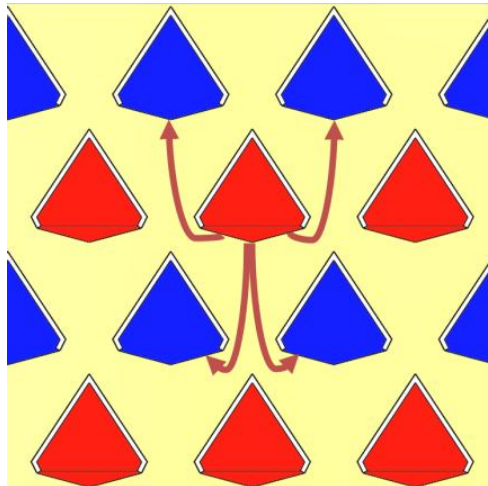

Figure 3. Operating principle of the drying cells.

The grain in the cells is constantly moving, flowing down between the triangular air ducts, getting mixed up efficiently. The grain temperature stays uniform.

Maintenance:

In normal conditions the drying cells do not require maintenance. Particularly moist grain and / or grains containing a lot of debris, can stick to the corners of the cells. Cleanliness of the cells can be checked through the maintenance hatch of the grain silo. Open the inspection doors of the feeding apparatus, so that lights can get in from below the drying cells. Normally it is possible to remove stuck grain by shaking the drying cells, for instance by hitting the cell walls with a piece of wood.

After the drying season:

- Open the bottom hatches of the feeding apparatus
- Switch off all fans
- Remove any debris

6.1.3. FEEDING APPARATUS

The task of the feeding apparatus is to ensure smooth flow of grain, and to adjust the flowing rate in the equipment. The rotating feed rollers between the ridges of the feeding apparatus feed grain into the bottom cone very precisely and uniformly. The grain flow rate can be modified by adjusting the rotating speed of the feed rollers with a frequency converter. The movable bottom hatches can be used to adjust the clearance between the roller and the hatch, and to ease the cleaning of the equipment.

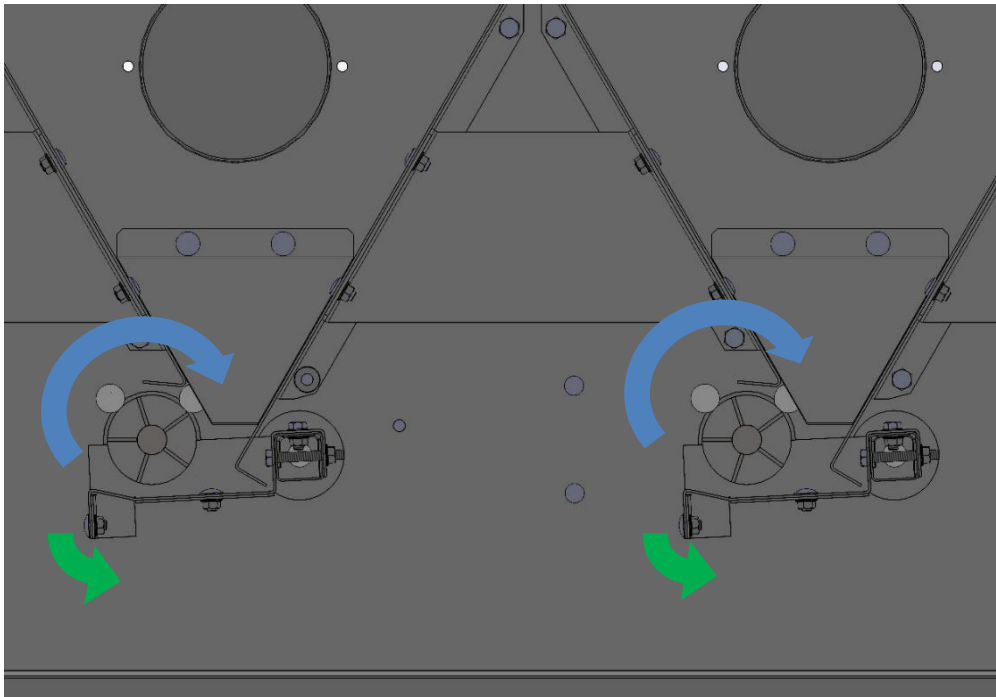

Figure 4. Operating principle of the feeding apparatus.

Adjustments

1. Capacity of the feeding apparatus

The capacity of the feeding apparatus is adjusted with a frequency converter from the display of the control panel.

Hz	Length of the feeding apparatus		
	2m	3m	4m
50	36	54	72
40	29	43	57
30	22	32	43
20	15	22	29

Capacity of the feeding apparatus [ton/h] with different frequency converter settings. The capacity was established with dry barley 650kg/m³.

The variety of the grain, as well as its moisture and debris content affect the capacity of the feeding apparatus. When the grain dryer is being commissioned, it is advisable to monitor the functioning of the elevator, and to adjust the feeding apparatus capacity in order to prevent the clogging of the elevator.

2. Clearance between the bottom hatches and the roller

There are movable bottom hatches under the feed roller. The clearance between the bottom hatch and the feed roller can be adjusted to minimize crushing of grain.

Clearance adjustment:

1. Fill the unit such that the bottom hatches are completely shut.
2. Cautiously open the bottom hatches (rotate the cam counterclockwise) until kernels start dropping into the bottom cone.
3. Rotate the cam one-quarter (1/4) of a turn towards closing (clockwise).
4. Start the drying process.
5. Do not forget to close the bottom hatches when the grain variety changes. The settings are variety specific.

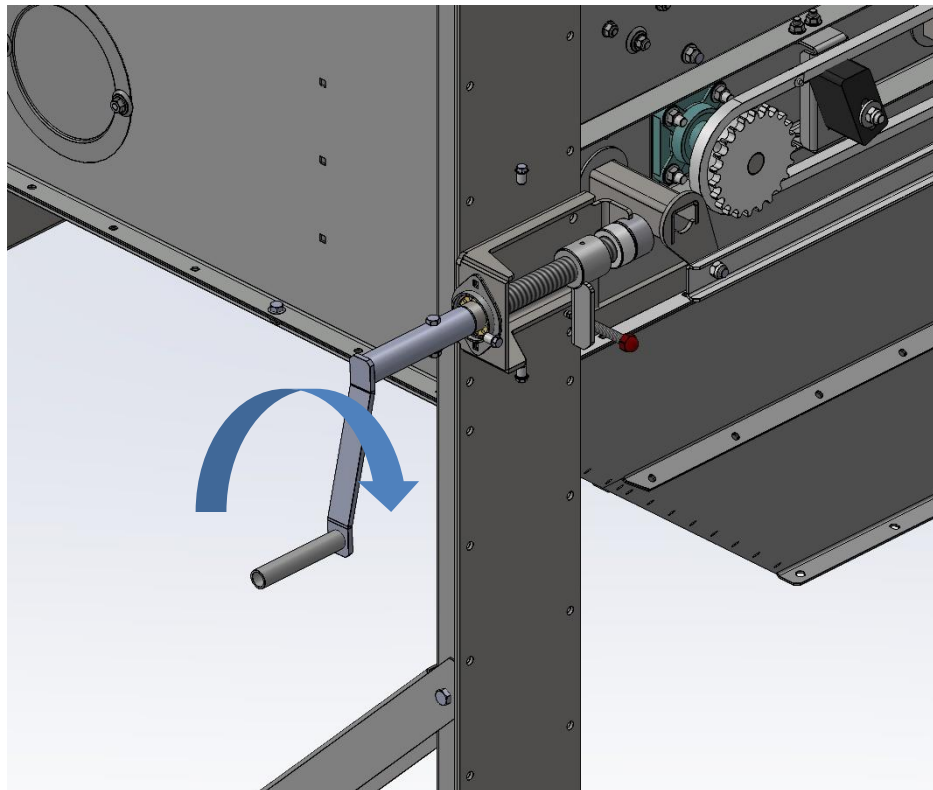



Figure 5. Closing the bottom hatches.

 **If the bottom hatches have been opened fully when there is grain in the equipment, they must not be closed before the machine has been emptied. Otherwise, there is the risk of damaging the mechanical parts of the bottom hatch.**

Cleaning

The feeding apparatus is cleaned after the drying season or during the season, if required.

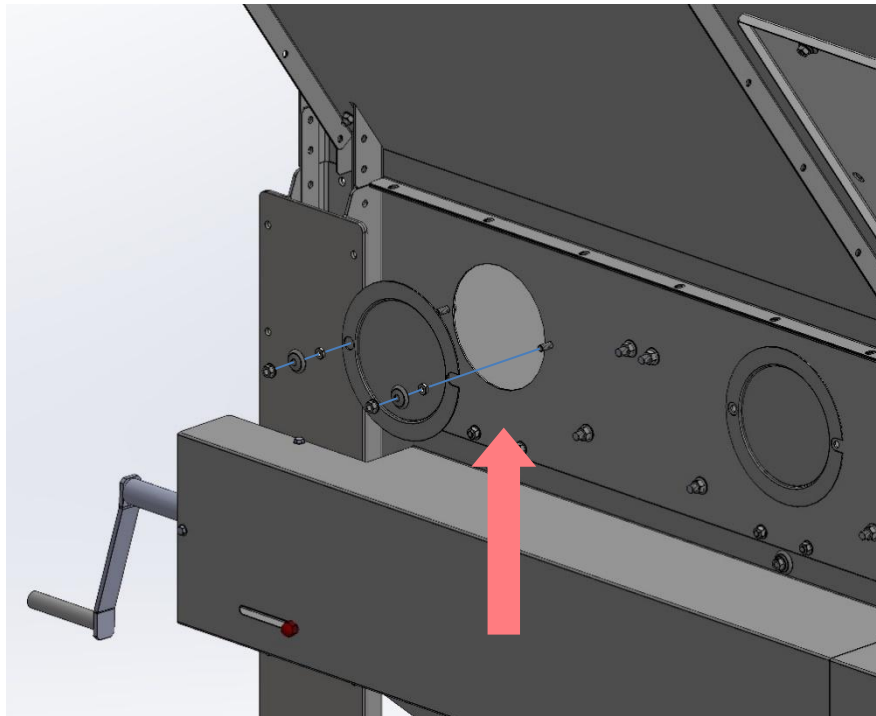

Figure 6. Inspection of the feeding apparatus

Check through the round hatches whether there is excessive debris or straw stock to the feed rollers. Scrub any possible dirt off. After the drying season, or if the dryer is left idle for a long time, leave the bottom hatches open to drain any water that has possibly penetrated into the dryer.

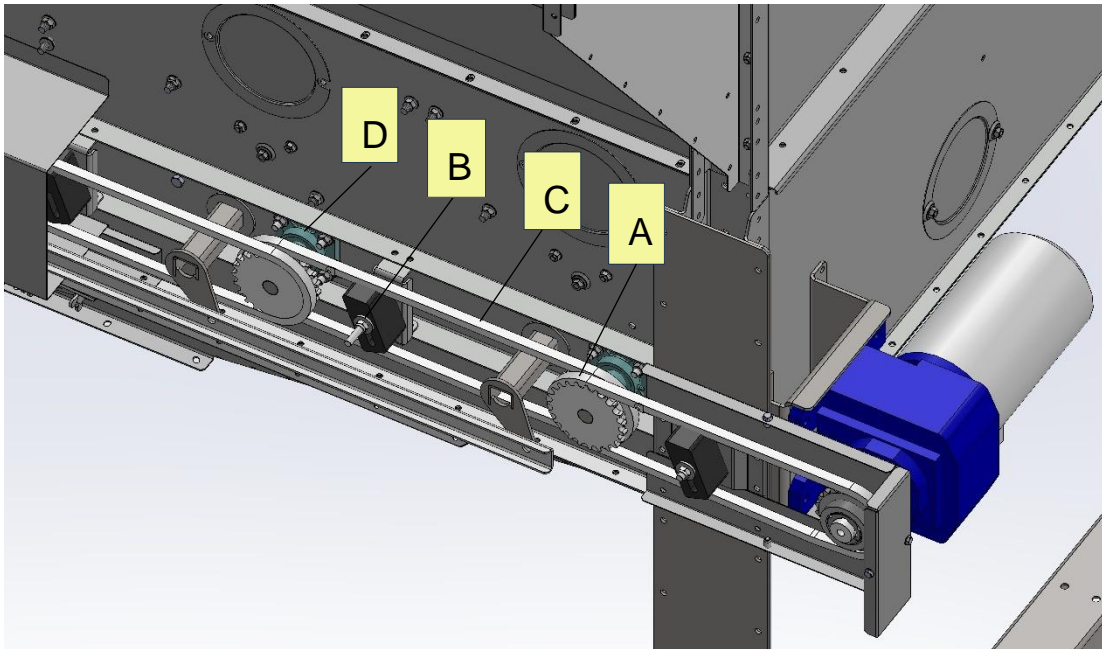

Figure 7. Maintenance points of the feeding apparatus (rollers drive unit side).

Maintenance

After the drying season:

- A. Check the tightness of the locking screws of the sprockets. If necessary, tighten with a 5mm allen wrench.
- B. Check the tightness of the elevator chain. Adjust the chain tightener, if necessary. If the tightener is out of tightening margin, cut one of the chain links off. Replace a worn chain.
- C. Lubricate the chain.
- D. Lubricate the bearings of the feed roller with the lubricant DIN 51825 or equivalent.

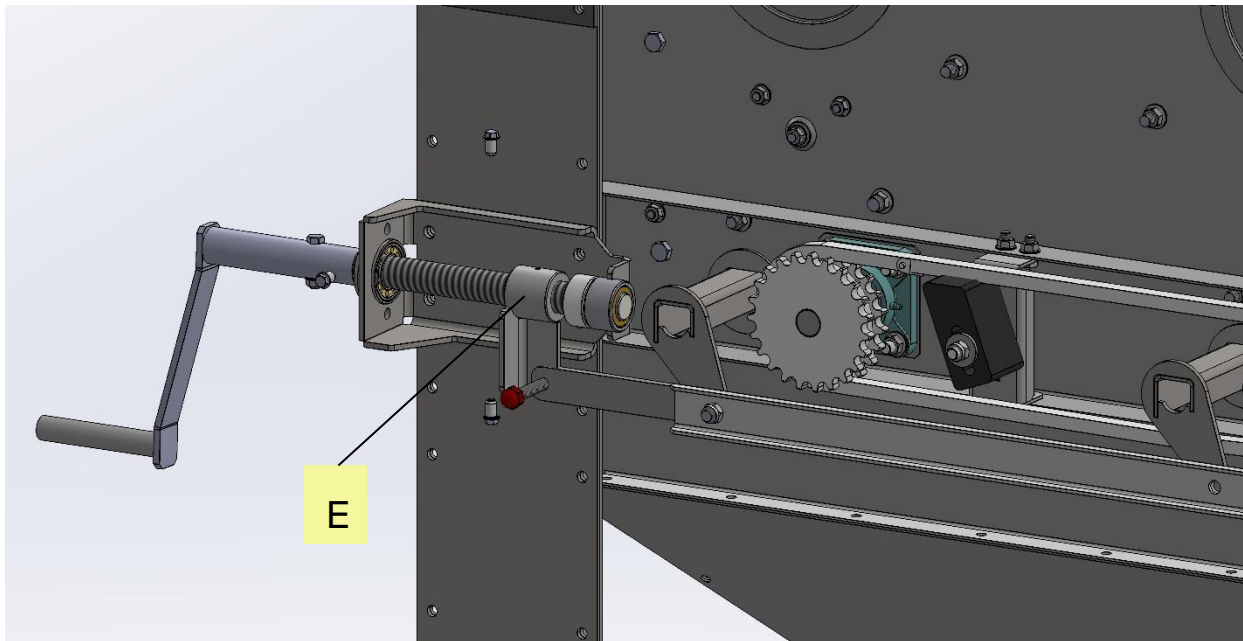
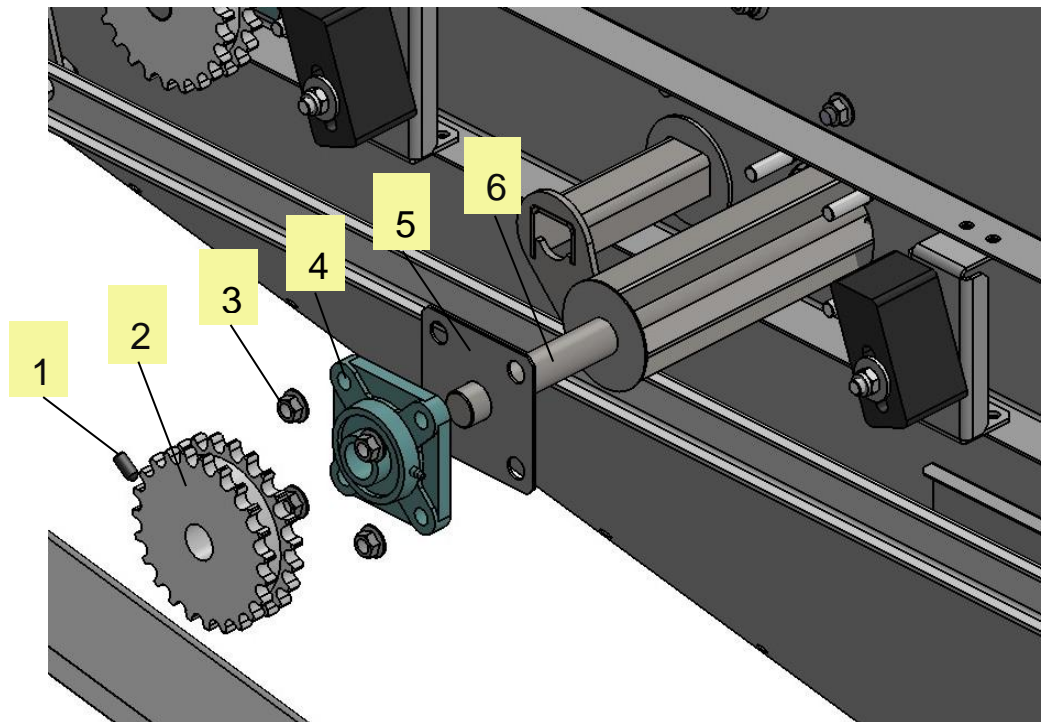

Figure 8. Maintenance points of the feeding apparatus (bottom hatches' drive unit side).

- E. Lubricate the opening device.
- F. Check the condition of the bottom hatches through the bottom cone
- G. Check the condition of the feed rollers to detect any dirt or damage. If any of the feed rollers are damaged, it should be replaced immediately to ensure smooth feeding of grain.

Replacement of feed roller



1	Sprocket
2	Bearing's fastening nuts
3	Bearing
4	Protective plate of the bearing
5	Shaft
6	Feed roller
7	Fastening of the roller to the shaft

Figure 9. The feed roller can be replaced in two ways:

1. By pushing the roller out from the hole in the bearing. The length of the roller is two meters, and therefore there has to be enough room on the other side of the unit to perform the work.
 - a. Open the bottom hatches.
 - b. Remove the chain. Note! If you intend to remove the roller from the bottom hatches' drive unit's side, it is also necessary to remove the chain and the sprocket.
 - c. Loosen the bearing's fastening bolts on the side where you intend to push the roller out.
 - d. On the other end of the roller loosen the screws that fasten the bearing to the shaft.
 - e. Tap the shaft of the roller with a hammer, and at the same time support the shaft from the other end. The shaft will slide out.
 - f. Loosen the fastening bolts of the shafts and remove the shafts.
- Install the new roller in the reverse order. Align the shaft.

2. By dropping the shaft into the bottom cone.
 - a. Open the bottom hatches.
 - b. Remove the chain and the sprocket.
 - c. Loosen the fastening bolts of the shaft.
 - d. Loosen the locking screws of the bearings.
 - e. Tapping with a hammer and install the shaft into the roller. The roller drops into the bottom cone.

When installing a new roller, support the roller from below and tapping on the shafts with a hammer move them in place. Note! Align the fastening bolts of the roller and the shaft before installation. In other respects, perform the operations in the reverse order. Align the shaft.

6.1.4. BOTTOM CONE

The bottom cone guides the grain falling from the feeding apparatus into the grain discharge hole. In case of a heat source operating with overpressure, it is advisable to use a small fan in the bottom through, which sucks out the heat and damp air coming into the bottom cone. The aspirator is installed instead of the ventilation grill (2). Air shall be led to the cyclone to minimize dust hazard.

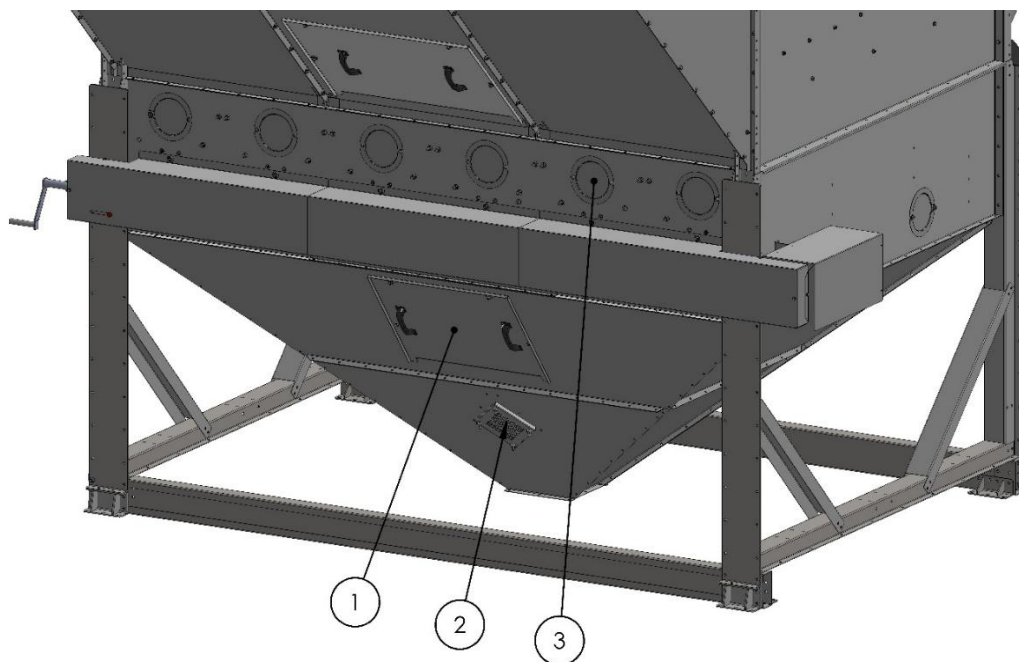

Figure 10. Bottom cone.

1	Manhole
2	Ventilation grill
3	Maintenance hatch

In negative-pressure units, negative pressure is formed in the bottom cone. In order to avoid excessive negative pressure, it is necessary to ensure sufficient current of replacement air.

6.1.5. AIR INTAKE AND EXHAUST CASINGS

The task of the air casings is to lead hot air from the heat source into the drying cell, and to lead the damp air from the exhaust side of the drying cell into the environment. When the equipment is being filled, some kernels can end up in the air casings. Such kernels are returned through the recovery openings in the bottom edge of the air casings back into the feeding apparatus.

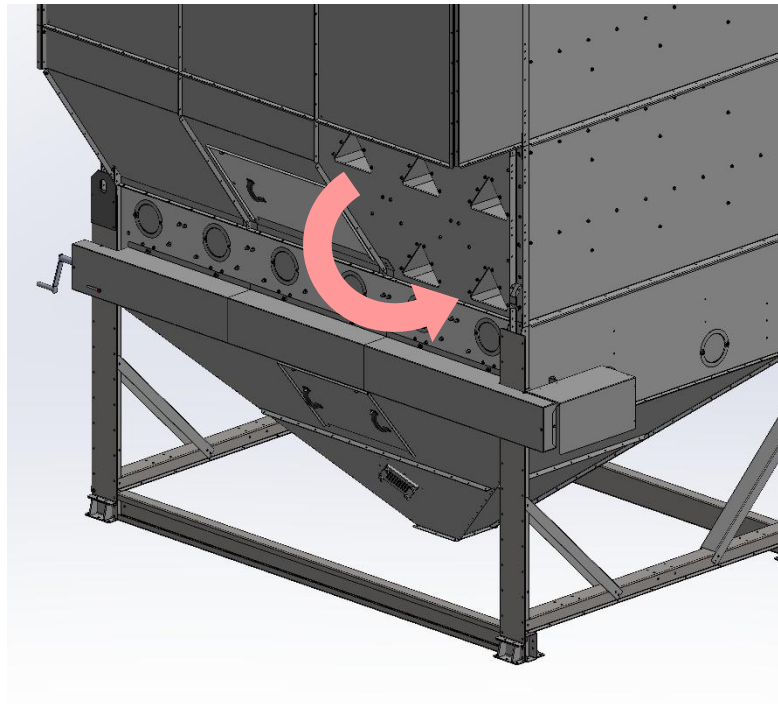

Figure 11. Return of kernels from the air casing.

Maintenance:

There are maintenance hatches in the bottom edge of the air intake and exhaust casings.

During the season:

- Regularly check and clean the air casings. The openings for returning the kernels falling into the air casing must be clean.
- When drying oil crops it is advisable to check and clean the air casings after every batch or in case of a continuous flow every 12 hours.
Risk of fire.
- When using a direct gas burner the air casings need to be checked and cleaned every 12 hours.
Risk of fire.

After the season:

- Check and clean the air casings. The openings for returning the kernels falling into the air casing must be clean.

6.1.6. AIR CASING ADJUSTMENT SHUTTER

A part of the air casing can be closed off with a shutter. There can be two reasons for closing off the air casing.

1. When the batch does not fill the machinery completely (partial batch drying) you can close off the upper drying cells. In this case air cannot escape through the empty drying cell but flows through the grain column instead.
2. In continuous flow dryers it is possible to shut off a part of the air intake casing, and to lead cold air into the part separated from the hot air casing. Cold air cools grain down before it is discharged from the equipment.

There are two types of air casing adjustment shutters available:

1. Manual air casing adjustment shutter:

The shutter is opened and closed with the chains suspended from the level attached to the shutter shaft.

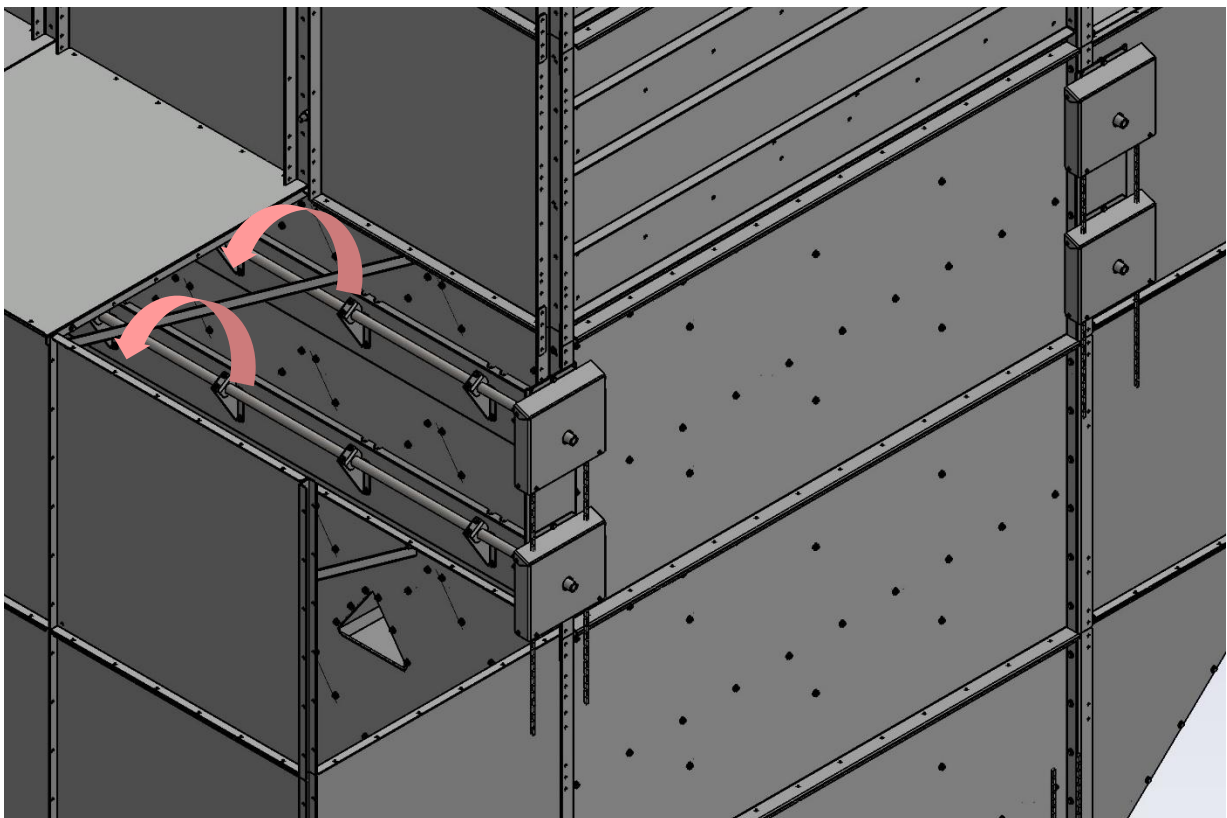

Figure 12. Air casing adjustment shutter (manual).

2. Electrically operated air casing adjustment shutter:

Controlled from the control panel of the grain dryer.

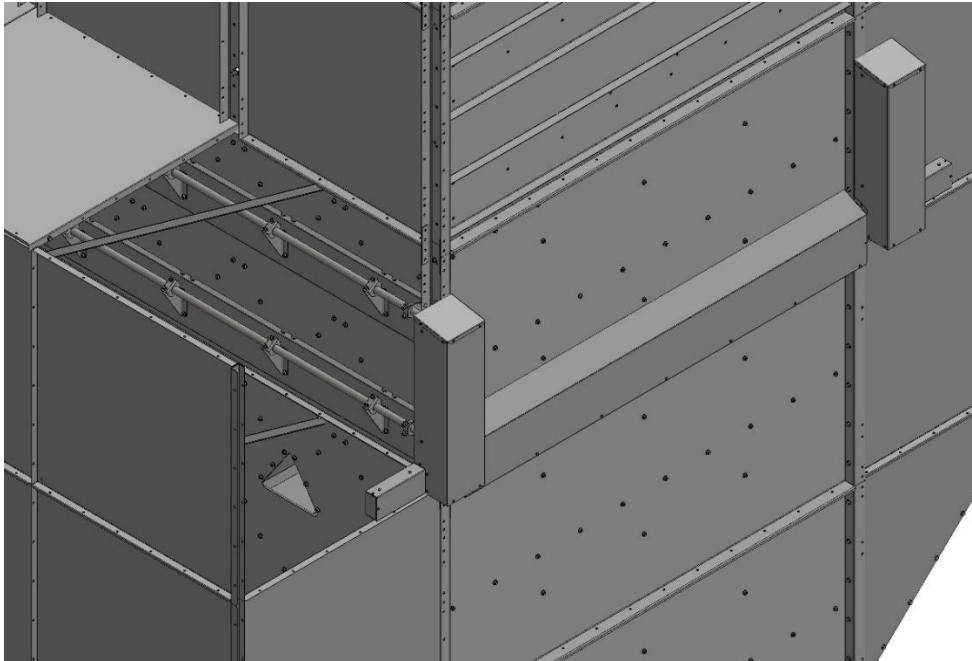

Figure 13. Air casing adjustment shutter (electrical).

6.2. BASE



The dryer machinery needs to be installed in a sufficiently strong and level foundation. Local conditions, such as wind, snow load and earthquakes, as well as local regulations need to be taken into consideration when determining the foundation.

There are two standard base heights available. The high base is used, when grain is delivered to the elevator using gravitation, and low base is used when the intent is to make the equipment as low as possible. In this case grain is fed onto the elevator with a conveyor.

6.3. LOADING OF THE GRAIN INTO THE DRYER AND UNLOADING

Grain is loaded into the equipment dryer unloaded from it either through channel or with conveyors. Often there is a divider at the top end of the elevator, which can be used to direct grain, in addition to the dryer machinery, also into e.g. the storage silo or into a transport vehicle / trailer.

6.3.1. GRAIN CHANNELS

Loading and discharging with grain channels is often the most cost-efficient way for moving grain. Replacement and modification of grain channels is also quite easy. For moist grain the channels have to be installed at a vertical angle of 45 degrees, and for dry – at an angle of 37 degrees. For this reason, grain cannot be led very far from the elevator.

If channels are used, it is advisable to rotate the channels regularly; this way is possible to move worn sections away from the flow of grain and increase the service life of the channels.

PART OF ARSKA GROUP

6.3.2. CONVEYORS

Grain can also be loaded into and unloaded from the dryer with conveyors, in which case the height of the equipment and the elevator is low.

Manuals for conveyors are supplied separately



Risk of being crushed.

Always turn off main power of the grain dryer before starting any maintenance procedures.

6.4. RECEIVING OF GRAIN

There are two different ways to receive grain:

1. A dump chute where grain moves by gravity. Grain is dumped into the chute from where it flows directly onto the elevator.



Risk of falling.

Cover the dump chute with a grill.

2. A hopper with a conveyor.



Risk of being crushed.

Always turn off main power of the grain dryer before starting any maintenance procedures. Cover the hopper with a grill.

There are several different dump chute and hopper types available in Mepu's procasing range. Their manuals are supplied separately.

6.5. PRE-CLEANER

The pre-cleaner separates dust and small debris from the grain with a powerful air current. The air current generated by the fan is led through the cyclone outside. The operating manual of the pre-cleaner is delivered with the pre-cleaner.

6.6. GRAIN SPREADER

The grain spreader spreads grain evenly across the grain bin. This facilitates the filling of the grain bin. There are two models available:

1. A rotating spreader. The spreader rotates below the roof of the grain storage. Grain falls onto the spreader and is thrown towards the walls of the grain storage. With this model grain can be spread uniformly across a symmetrical grain storage.
2. Spreader conveyor. The conveyor installed on the roof of the grain storage features a number of unloading openings. By adjusting the size of the openings grain can be divided evenly over a long grain storage.

The grain spreader manuals are delivered with the grain spreader.

6.7. AIR DUCTS



Air ducts deliver hot air from the furnace into the intake channel of the dryer machinery and possibly lead moist air from the exhaust channel outside the dryer. The content of the delivery set depends on the furnace type and the installation place.

The following should be taken into consideration when designing the ducts:

- The channels and, in particular, the elbows create counter-pressure. As the counter-pressure increases the air current gets weaker.
- Heat loss of the pipeline at the intake side.
- At the exhaust side the moisture in the exhaust air can start to condensate.
- It must be possible to clean the air ducts. There has to be a coupling installed before the furnace, which is used for cleaning and also functions as a trap for kernels and debris that can potentially get into the air duct.

Maintenance:

During the season

-  - Regularly check and clean the air ducts.
-  - When drying oil crops it is advisable to check and clean the air ducts after every batch or in case of a continuous flow dryer, every 12 hours. **Risk of fire.**
-  - When using a direct gas burner the air ducts need to be checked and cleaned every 12 hours **Risk of fire.**

After the season:

- Check and clean.

6.8. FANS

Fans blow air from the heat source into the drying cells, and moist air out from the dryer. The number and the capacity of the fans depends on the model of the dryer machinery.

There are two types of fans available:

1. An axial fan can be installed directly onto the air chamber wall without any support structures.
2. A centrifugal fan has to be supported either onto the possible dryer building or on the ground with support legs.

The manual for the fan is delivered separately.

6.9. LADDERS AND STEPS

Ladders and steps provide safe access to the maintenance points of the dryer and onto the roof of the equipment.

6.10. MAINTENANCE PLATFORMS

Maintenance of the grain dryer and inspection of its functions can be safely carried out from the maintenance platform.

6.11. ELEVATOR

The elevator lifts the grain into the grain bin and / or the unloading location.

Generally, Mepu dryers are delivered with a Skandia bucket elevator. Manual for the elevator is delivered separately.



Risk of being crushed.

Always turn off main power of the grain dryer before starting any maintenance procedures.

6.12. HEAT SOURCE

The heat source raises the temperature of the air used for drying. The heat source alternatives include:

1. An overpressure furnace. There is a fan before the furnace that generates overpressure in the equipment.
2. A negative pressure furnace. The furnace itself does not have a fan. Fans are installed in the air exhaust duct, and they generate negative pressure in the equipment.
3. Direct gas burner. Combustion of gas takes place in the intake air – no separate heat exchanger.
4. Radiator.

The heat source is selected based on the required air current, the drying temperature and the outdoor temperature, as well as the available fuel option.

See the separate manual for the heat source.

7. COMMISSIONING



Before commissioning the grain dryer it is necessary to perform the following:

What	Task	How
Assembly of the dryer machinery	Check the parts of the dryer machinery	<p>Check that all the parts of the dryer machinery have been assembled according to the assembly instructions.</p> <p>Pay particular attention to:</p> <ul style="list-style-type: none"> - Watertightness of the roof structure if the equipment is installed outdoors - Airtightness of the air ducts - Tightness of bolts – loose bolts and nuts can fall off
Assembly of the dryer machinery	Check the fastenings of the frame	<p>Check that all bolts and nuts of the frame are tightened.</p> <p>Check that the stands of the equipment have full contact with the base and that they are fastened securely.</p>
Foreign objects	Check the insides of the dryer machinery, the conveyors and the elevator	<p>Open the maintenance hatches.</p> <p>Check that there are no foreign objects inside the equipment, e.g. bolts and nuts.</p>
Electrical connections	Check the connections	<p>Check that the connections are made properly.</p> <p>Check that the motors rotate in the right direction.</p> <p>Check the instructions of the control system.</p>
Heat source	Check the fuel couplings	<p>Make sure that none of the fuel couplings are leaking.</p> <p>See the manual for the heat source.</p>
Heat source	Check the air intake	<p>Check and clean the air intake of the heat source of any debris.</p>

8. MAINTENANCE DURING THE DRYING SEASON



Before starting any maintenance procedures turn off main power.

What	Task	How	When
Heat source RISK OF FIRE 	Check / clean	Open the maintenance hatches and remove possible debris. Check for fuel leaks. See the manual for the heat source.	Regularly. When drying oil crops – after every batch or in case of a continuous flow dryer, every qw hours. Direct gas burner – every 12 hours. See the manual for the heat source.
Air ducts RISK OF FIRE 	Check / clean	Open the maintenance hatches and remove possible debris.	Regularly. When drying oil crops – after every batch or in case of a continuous flow dryer, every 12 hours. Direct gas burner – every 12 hours.
Elevator and conveyors	Monitor	Listen and check for strange noises. Make sure that the elevator belt is running in the middle. Open the maintenance hatches and clean, if necessary.	Continuously. Check the operating manual for the elevator and the conveyors.
Feeding apparatus	Monitor	Feed rollers: Check that all feed rollers are rotating. Tray feeder: Check that the tray is moving.	In batch dryers during the drying of each batch. In a continuous flow dryer - every 12 hours.
Level guard	Check	Check that the level guard is working.	Regularly.

9. MAINTENANCE AFTER THE DRYING SEASON



Before starting any maintenance procedures turn off main power.

What	Task	How
Cleaning of the dryer machinery	Remove debris and any grain possibly left in the equipment.	<p>Open the bottom hatches of the feeding apparatus. Keep them open when the dryer is not being used.</p> <p>Check through the maintenance hatches whether there is any debris or grain remaining in the machinery. Brush / knock any possible dirt stuck to surfaces. Switch on the feeding apparatus.</p> <p>Run the main fan with the maximum air flow intensity.</p>
Cleaning of the elevator	Remove any grain left in the elevator stand.	<p>Open the maintenance hatch of the elevator stand.</p> <p>Remove any grain and debris from the stand by scrubbing.</p> <p>See the operating manual for the elevator.</p>
Cleaning of the heat source	Remove dust and debris.	<p>Open the maintenance hatches.</p> <p>Remove any debris and use a brush / knocking to remove any dust. Run the main fan with the maximum air flow intensity.</p> <p>See the manual for the heat source.</p>
Cleaning of the air ducts	Remove dust and debris.	<p>Open the maintenance hatches.</p> <p>Remove any debris and use brush / knocking to remove any dust. Run the main fan with the maximum air flow intensity.</p>
Fans	Check / clean	Check the condition of the fan blades and clean if necessary.
Feeding apparatus	Grease / lubricate / check	Lubricate the bearings and chains. Check the locking of the sprockets and tighten if necessary.
Electrical equipment	Check	Check the power cables and the electrical equipment. Repair / order the repair of / replace any damaged cables and equipment.
Motors	Check / clean	Check the condition of the motors. Clean the cooling ribs.
Pneumatic equipment	Check / repair	Check the pneumatic equipment and repair any possible defects.
Grain dryer	Clean	Brush / wash / vacuum the grain dryer. It is nice to start the new season with a clean machine!

10. TROUBLESHOOTING



Before starting any maintenance procedures turn off main power.

Problem	Possible cause	Remedy
There is some grain left in the machine	The feed roller(s) is (are) not rotating	<p>Check the chains.</p> <p>Check the fastening of the sprockets to the roller shaft.</p> <p>Check the rollers.</p>
	Clogging	<p>Check the bottom cone. Knock on the sides of the bottom cone. If the bottom cone is empty, open the manhole of the bottom cone.</p> <p>Check the feeding apparatus. Knock on the round inspection hatches of the feeding apparatus. If the feeding apparatus is empty, open the inspection hatches.</p> <p>Check the drying cells. Knock on the sides of the drying cells.</p> <p>Check the air chambers. Knock on the bottom of the air chambers. Carefully open the maintenance hatches, if there is any grain inside. Clean the grain recovery openings in the bottom edge of the air chamber.</p>
The elevator gets clogged	The elevator belt is loose.	Tighten the belt. See the manual for the elevator.
	The grain intake capacity is too large.	<p>On hoppers with a container reduce the container capacity</p> <p>On models with dump chutes, close the elevator's shutter.</p>
	The capacity of the bottom auger of the machine is too large.	<p>Adjust to reduce the capacity of the feeding apparatus.</p> <p>Reduce the capacity of the bottom auger.</p>
	The pre-cleaner gets clogged.	<p>Check the vertical position and functioning of the level guard.</p> <p>Reduce the grain flow fed onto the elevator.</p> <p>If the humidity level is high, the pre-cleaner can get clogged when the dryer is started, because humidity on the surface slows the grain flow down. See the manual for the pre-cleaner.</p>

	The level guard is malfunctioning.	Check the functioning of the level guard. Clean the probe of the sensor
	The channels at the unloading side are too narrow.	Recommended channel sizes: <ul style="list-style-type: none"> - 60ton/h -> 200mm - 80-120ton/h -> 250mm Check the channel angles. The recommended vertical angle for moist grain is 45 degrees.
	The divider is not working	Check whether the divider discs move normally from one position to another.
	The feeding couplings at the bottom are too low.	Check the position of the elevator's feeding couplings. If the couplings are too low, grain does not flow normally onto the elevator. See the manual for the elevator.
In an overpressure dryer there is too much debris on the cover of the grain bin.	The overpressure in the grain bin is too high.	Excessive overpressure in the grain bin causes air to flow, for instance, to the cover of the pre-cleaner. In this case much debris is carried onto the cover. Check the channels at the discharge side. If at the discharge side the channels are too long or if there are many bends, it is advisable to install an additional fan to the discharge side to suck air out from the machinery. Reduce the air flow of the furnace fan.

11. DRYING OF DIFFERENT GRAIN VARIETIES

Different grain varieties require drying methods. Based on testing and experience it is possible to find the settings and the drying methods, which are the best suited for the local conditions and varieties. Below you can find indicative information, which you can use as the basis for your search for the optimum drying method.

Variety	Varehousing humidity [%]		Seed grain	Marketable grain	Fodder grain	Air volume *	Dryer machinery cleaning interval [h]		
	<6months	>6months	°C	°C	°C		6	12	24
Sunflower	11	10	45	50		1,5	x		
Sunflower (oil)	10	8	45	50		1,5	x		
Durra	13,5	13	45	50	90	1			x
Peas	16	13	45	70	80	1,5			x
Millet	10	9	45		90	1			x
Oat	14	12	50	60	100	1			x
Corn	15,5	13	45	70	100	1,5			x
Barley	14	12	45	55	100	1			x
Flax			45	80	100		x		
Rice	14	12	45	60		1		x	
Rye	14	12	45	60	100	1			x
Turnip rape	9	7	45	65		0,5	x		
Mustard	9	8	45	60		0,5	x		
Soy	13	11	45	65	80	1,5		x	
Buckwheat	14	13	45	65		0,5			x
Wheat	14	13	60	65	100	1			x

* *Relative air volume.*

12. EC DECLARATION OF CONFORMITY OF THE MACHINERY

Vaatimuksenmukaisuusvakuutus
Declaration of conformity
Garanti av motsvarighet



Laite, Machine, Maskin:

Viljankuivaamo, Grain dryer, Spannmåls torkeri

Laitteen tyyppimerkintä, Type of machine, Typmärkning:

S2-xxx, S3-xxx, S4-xxx, S5-xxx, S6-xxx

M2-xxx, M3-xxx, M4-xxx, M4-xxx, M5-xxx, M6-xxx

C2-xxx, C3-xxx, C4-xxx, C5-xxx, C6-xxx, C7-xxx, C8-xxx, C9-xxx, C10-xxx

(xxx=koneen koko)

Direktiivit, Directives, Direktiv:

2006/42/EC, 2004/108/EC, 2006/95/EC

Standardit, joita on sovellettu (tai niiden osia/kohtia), joita on sovellettu
(Part/clauses of) standards that has been used,
(Delar/paragrafer av) standarder som har använts:

SFS-EN 349 +A1, EN 547-1 +A1, EN 547-2 +A1, EN 547-3 +A1, EN ISO 12100, EN ISO 13849-1, EN ISO 13850, EN ISO 13857, EN ISO 14122-2 +A1, EN ISO 14122-4 +A1, EN 60204-1:2006, EN 61439-1, EN 61439-2

Muut tekniset standardit, (tai niiden osia/kohtia), joita on sovellettu
(Part/clauses of) other technical standards that has been used,
(Delar/paragrafer av) andra tekniska standarder som har använts:

EN 953

Sisäisellä laadunvalvonnalla on varmistettu, että tässä eritelty laite vastaa nykyisten direktiivien ja standardien vaatimuksia.

Trough our internal quality control it is ensured that the product which this declaration relates is in conformity with the current directives and standards.

Genom inre kvalitetsgranskning försäkras att de produkter som nämns i detta certifikat är i enlighet med de nuvarande direktiv och standarder.

Lauri Jokela Suunnittelupäällikkö, Design manager, Design chef

14.4.2025 Yläne





PART OF ARSKA GROUP



PART OF ARSKA GROUP



Mepu Oy Service:
Tel. (02) 275 4482
E-mail: service@mepu.com

Mepu Oy, Mynämäentie 59, 21900 Yläne www.mepu.com